



EkoTek System Installation and Configuration Manual

**Survey
Installation
Configuration
Maintenance**

9261-8173 Issue 7

Table of contents

Table of contents	i
Approvals	4
Compliance	4
FCC and Industry Canada statement of compliance	4
WEEE Directive and product disposal	4
System overview	5
EkoTek principles	6
Alarms	8
Location alarm	8
Beacons	8
Two-way acknowledgement	9
Two-way radio	9
Frequency hopping	9
ESPA 4.4.4 and TAP paging I/O	9
Configuration	10
Network parameters	10
Diagnostics and statistics	10
Components	11
Hub	11
Repeater	11
Solar repeater	12
Call point	12
Call fob	13
Pager	13
Quad pager charging rack	14
Network design and survey	15
Overview	15
Prerequisites	15
Placement rules	15
The survey unit	16
Survey pager modes	17
RSSI	17

Quality	17
Network monitoring mode.....	18
Channel activity	18
Repeater information	18
Out of range location beacon	19
How to survey	19
Installation.....	20
Preparation	20
Installing the hub and IP slave hub.....	21
Installing the repeater and call point.....	22
Installing the solar repeater.....	26
Installing the PPP modem.....	28
Installing the 4 way pager charging rack.....	33
Browser interface setup	35
Initial setup	35
Connecting the hub to the PC using Windows XP	35
Using the web browser to access the hub.....	38
Password.....	38
Main menus	39
Day/Night.....	39
Event log.....	40
Page device.....	41
Pager log	41
Location.....	41
Maintenance menus	42
Device status	42
Device status - hub and IP slave hub	42
Device status - repeater, solar repeater and call point.....	43
Device status - call fob and pager	44
Configuration menus.....	44
System settings - hub	44
System settings – IP slave hub	47
Radio settings.....	48
Devices.....	50
Device mode.....	53

Pager groups	60
Alert rules	61
Factory reset.....	65
Delete all devices	65
Passwords	65
Archive.....	66
Final checks	68
Appendix 1: Miscellaneous system messages	69
Personal security messages	69
Pager response messages	69
Maintenance messages	69
Appendix 3: RS232 cable pin-outs for connecting the modem to the hub	71
Appendix 4: Overlapping system support	72
Overview	72
Overlapping and mobile roaming systems.....	74
Automatically setting up a multiple hub ‘overlapping’ system	75
Network 1	75
Network 2	75
Automatically setting up a ‘mobile roaming’ network	76
Network 1	76
Network 2	76
Manually setting up a multiple hub overlapping network or a mobile roaming network	76
Preparation	76
Setting up the networks	76
Putting into service	77
Appendix 5: Remote logging protocol	78
Overview of logging	78
General formatting	78
Log examples	81
Appendix 6: External system connections	83
Revision history and related documentation	84
Revision history	84
Related documentation.....	84

Approvals

Compliance

This product complies with the requirements of the EU Radio & Telecommunications Terminal Equipment Directive 99/5/EC.

FCC and Industry Canada statement of compliance

This device complies with Part 15 of the FCC Rules and Industry Canada Standard RSS 210.

Operation is subject to the following two conditions: (1) this device may not cause harmful interference and (2) this device must accept any interference that may cause undesired operation.

Unauthorised modification to this equipment will void the user's authority to continue to operate the device within the scope of the Industry Canada and FCC Part 15 Rules.

A full technical specification for this product may be obtained from your Multitone representative.



WEEE Directive and product disposal

At the end of its serviceable life, this product should not be treated as household or general waste. It should be handed over to the applicable collection point for the recycling of electrical and electronic equipment, or returned to the supplier for disposal.

System overview

EkoTek's personal security system consists of mobile devices that send assistance messages to other fixed or mobile devices, where the assistance message and location of the caller are displayed:

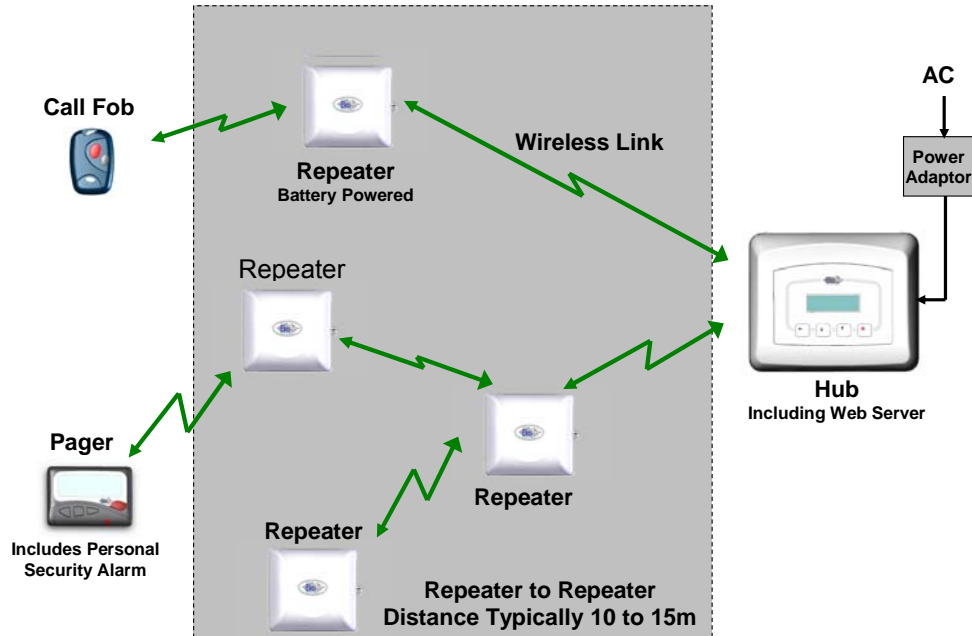

Messages are communicated via a backbone radio network, which makes use of repeaters to relay messages around the network.

Due to the multi-hop nature of the backbone network, the physical shape and size of the network is defined by the layout of the repeaters, which may be in three dimensions e.g. covering multiple floors in a building.

EkoTek is truly wireless (only the hub needs AC power), making installation and expansion very quick and easy.

EkoTek principles

Each EkoTek product is a node that forms part of a self-organising radio mesh network:

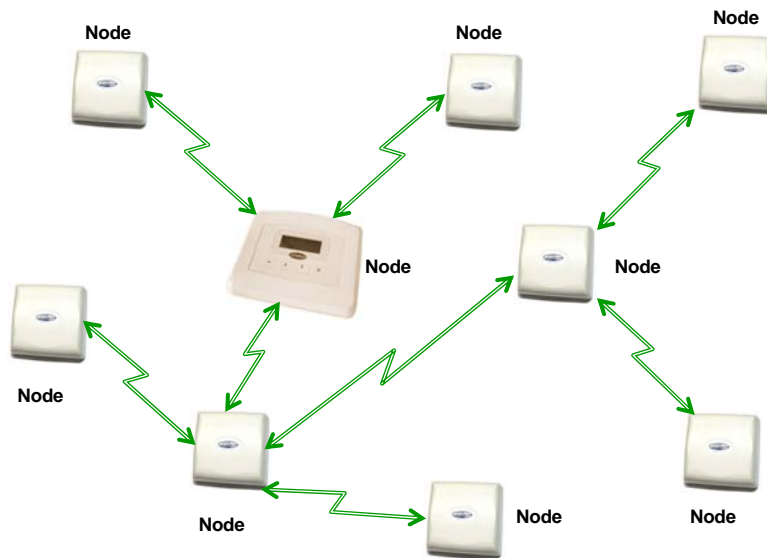

Each node in the network searches for links to nearby nodes, to form the network mesh. Organising the network is an automatic function carried out by the nodes themselves – configuration is not required.

As the network is self-organising, it is also self-repairing. Should a node (repeater) fail, the network will automatically reconfigure around the failed node:

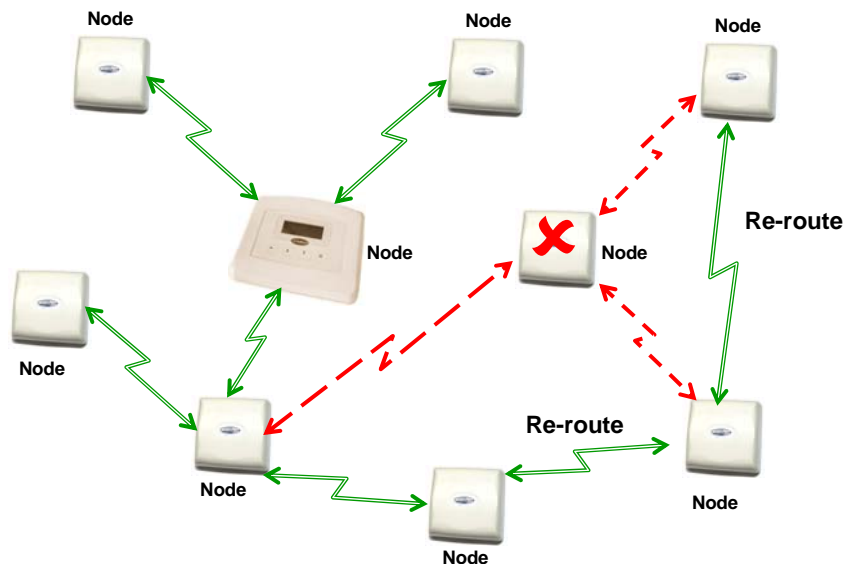

The dimensions of the network are defined by the layout and distribution of repeater nodes, the layout being arranged to meet the requirement, e.g. reception and public areas of a hospital, accident and emergency department, or all floors of a building for security guard lone-worker protection.

Sizeable networks can be easily built, due to the large number of repeaters supported by EkoTek.

Repeaters are normally installed on walls and/or ceilings. The hub is installed either on a wall or on a desk, so that the display can be easily seen:

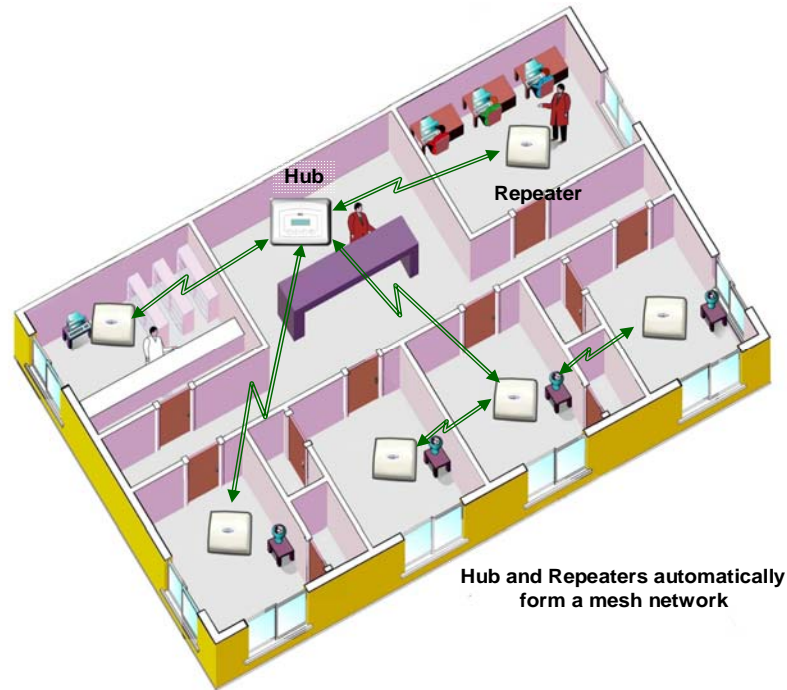

Location reporting

When a user raises an alarm signal, it is important to know the location of the user to ensure that assistance arrives as quickly as possible.

EkoTek provides accurate location reporting, based on location signals sent out by the repeaters:

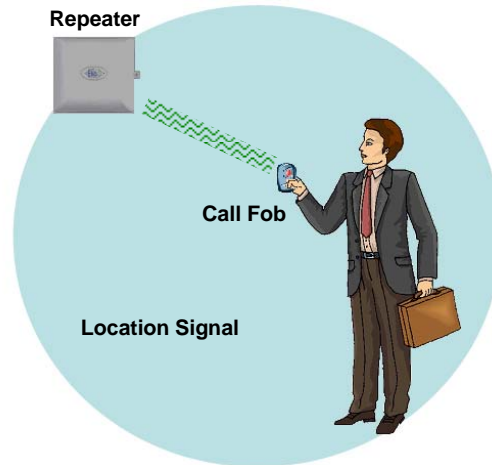

Alarms

A user may manually signal an alarm by pressing the red button on a pager or call fob, or alarms may be triggered automatically for man down, dead man or location alarms. When an alarm is triggered the user identification (name), location and alarm type are included in the alarm message displayed on the hub and sent to pagers.

Location alarm

The location alarm feature allows pagers and call fobs to automatically raise an alarm should the device wearer enter a location where the local repeater indicates an unauthorised zone. Applications include 'resident wander', where an alarm would be raised if a resident wandered into a zone where they were not expected or not allowed, and 'contractor/visitor' location alarm where an alarm would be raised if a person entered a part of the building that they were not authorised to access.

Beacons

Beacon signals are used to update a device with information of who its parent is. The hub and all repeaters regularly transmit two types of beacon – system beacons and location beacons, which generally have a shorter range than system beacons. A repeater, pager or call fob can only ever have one parent at a time. Every 1000ms the repeater transmits to the pager or call fob, which is then updated with its location and will continue to receive subsequent beacons from the repeater (its parent). If the pager stays within range of the location beacon, '= [location name]' (for example, '= Conference Room 1') will be shown on the pager's display. If the pager goes out of range of the location beacon but can still receive the system beacon, '- [location name]' will be shown instead, where [location name] is the name of the last location beacon received. When a pager or call fob receives a new location beacon it picks up location information from the new repeater and updates itself with the new location.

Two-way acknowledgement

Messages from external systems and maintenance messages are one-way messages from the hub to the pager, whereas alarms generated by a user are two-way. For peace of mind of the user, the acceptance of an alarm at the hub or a pager by someone who will be going to the aid of the user is signalled back to the user by the call fob lamp and beeper changing their alert patterns, or by the pager display indicating the status of the alarm.

Two-way radio

All EkoTek radio links are two-way, providing the ability to signal both to and from all devices on the network.

Two-way radio provides the ability to quickly detect and correct any lost messages. For example, when a message is relayed from one repeater to a second repeater, the second repeater will acknowledge receipt of the message. If the first repeater does not receive an acknowledgement it retransmits the message. This ability allows EkoTek to function, even in environments where there is radio interference or poor signal.

A further benefit of two-way radio is the ability to download configuration parameters to all devices from the hub, using over-the-air programming. Devices do not hold their own configuration, as this is sent by the hub upon request when devices are powered up. Even pagers and call fobs have their configuration held at the hub, making it unnecessary to recall mobile devices for configuration change, as all updates are made centrally at the hub.

Frequency hopping

EkoTek radio links can be configured to operate on a fixed frequency, or to hop across all 16 available frequencies. Frequency hopping increases the immunity of EkoTek systems to radio interference. If a message is lost due to interference on a frequency, the loss is immediately detected and the message retransmitted on the next frequency in the hopping sequence.

Frequency hopping is especially useful where the local radio environment may be unknown, or subject to change. EkoTek's combination of message loss detection, automatic message retransmission and frequency hopping, makes for a very robust radio infrastructure.

ESPA and TAP paging I/O

In addition to the in-built support for EkoTek 2-way pagers, the hub provides the ability to connect the EkoTek system to external systems via a 1-way paging interface. This allows the EkoTek system to either receive or to send messages to a pre-existing 1-way paging system

The hub paging interface can be selected from ESPA or TAP as an input or output (but not both simultaneously). This allows EkoTek to be used as a paging system, e.g. for connection to a nurse call system or to send messages to a pre-existing 1-way paging system.

Configuration

All configuration of the EkoTek system is performed via web pages stored on the EkoTek Hub. Access to this web server is either via the 10/100Base-T Ethernet port or using PPP via an RS232 serial port. Configuration for all devices is held on the hub and downloaded to each device at power-up.

The hub defaults allow a new system to operate 'out-of-the-box', only requiring the location names for the repeaters and user names for the mobile devices to be entered on the hub's web server configuration page.

Each device has its own unique factory set serial number for identification, but there is no factory programming of the devices. The hub configuration set for the devices during installation defines whether device options (e.g. the man down alarm) are enabled or not.

Network parameters

An EkoTek system controlled by a single hub is able to support up to 500 devices. See Appendix 2: Specifications (page 70) for maximum numbers for each type of device.

The network radio channels can be configured using the hub web server interface, with up to 16 channels being available for simultaneous use by a single EkoTek system and hub. The default configuration is for all EkoTek devices to use channel 15. See the Multitone document 'Example EkoTek System Configurations' for more information on special configurations.

A single EkoTek radio channel supports up to 90 repeaters. The repeaters can be configured in any physical deployment, as long as each repeater is able to establish and maintain a suitably strong signal with a nearby repeater that has a path back to the hub.

Diagnostics and statistics

Each EkoTek device collects statistics on network performance. These statistics are regularly sent to the hub and can be viewed using the web server.

Failure (e.g. loss of network coverage) and battery low indications for EkoTek devices are displayed on the status screen of the web interface; these messages are also reported on the hub and/or pager displays if the option to do this is configured.

Components

Hub



The hub is the central device in the mesh network. All communications pass to and from the hub; ideally it should be installed near the physical centre of the network, but it can be located anywhere within the network.

A hub display shows alarm messages in a similar way to a two-way pager.

For configuration, a PC running a web browser is connected via Ethernet to the web server running on the hub.

Other connections on the hub are for alarm relay contacts, external systems, web access using PPP, and power input.

Internal rechargeable batteries allow the hub to function for several hours should the AC power fail.

For more information on front panel operation of the hub see 9621-8276 EkoTek Hub User Guide.

Repeater and mains powered repeater



Repeaters form the backbone of the self-organising radio mesh network. Each repeater automatically forms links to nearby repeaters, to allow messages to pass across the backbone. Two screws hold the repeater on a ceiling or wall. Two internal alkaline D size batteries power the repeater. The battery voltage is continuously monitored and reported to the hub and/or pagers, raising an alarm should the voltage fall, indicating that the repeater batteries require replacement.

The mains powered repeater is functionally similar but provides terminals for wiring to an external low voltage DC supply and contains an internal rechargeable battery pack for battery backup in case of supply failure.

Repeaters also transmit location beacon signals, which are used by the mobile devices to determine their location, which is sent when assistance messages are generated.

Repeaters may form the mesh network in 3 dimensions, with repeater radio links able to pass through walls and ceilings if necessary.

By default, all repeaters operate on the same radio channel as the hub. This is the default configuration used by most systems and it is not normally necessary to change from this.

However, where there is a need to force repeaters to make links to other specific repeaters – for example, when a building-building link is required and this is specifically required to be above the height of passing vehicles – repeaters can be configured at the hub to operate only on specific channels. See the Multitone document ‘Example EkoTek System Configurations’ for more information on ‘special’ configurations.

Battery replacement for the repeater is quickly achieved by sliding the repeater from the backing plate and lifting out the old batteries. No tools are required for this. An optional locking screw can be inserted where necessary to help prevent tampering with the repeater – for example, where the repeater is installed in a public environment, within reach of passers by.

Repeaters continually test links to adjacent repeaters, detecting link failures and automatically searching for and establishing a new links should one fail.

Network moves and/or expansion are achieved by moving or adding new repeaters where required, making any network changes rapid and cost effective.

Solar repeater



The solar repeater is based on the standard repeater, with the additional functionality of power obtained from an integral solar panel with a rechargeable battery acting as a power reserve in periods of low light. It can therefore operate in full sun or shade provided that it receives enough solar radiation to charge the battery sufficiently for the unit to continue to operate in periods of low light.

The solar repeater is dust and water resistant to IP65 and UV and corrosion proof, and can be mounted on a wall or pole.

Call point



The call point allows alarms and assist calls to be raised by a red button on the front of the unit or an external closing contact input.

A call point can be used to connect to equipment that has a closing contact (a simple switch such as a ceiling mounted pull cord) to signal an alarm.

The assist message is configurable separately for the red button and external contact input.

The call point has an internal sounder (configurable on/off) to indicate call state.

The red button can be configured as:

- Disabled

- Single press raises alarm
- Double press raises alarm

A long press of the red button always clears an alarm raised by the red button or the external alarm contact.

The call point can also be used as a repeater while still retaining call point functionality. For mounting positions where the unit is at body height this is not recommended, as the quality of link that the call point can offer will degrade when someone stands near the unit. This may cause devices communicating through the call point to lose contact with the network. For high positions such as operating in conjunction with a ceiling pull cord this should not be a problem.

Another situation where repeater operation may be acceptable even if the unit is at body height is to allow the unit to be a repeater for mobile devices only. This can be achieved by setting the call point's 'Downstream channel' to a channel that other repeaters cannot use as an 'Upstream channel'.

Call fob



The call fob allows assistance calls to be raised, using the location signals from repeaters for accurate location determination. The call fob also supports dead man, man down and location alarms.

The configuration of the call fob is downloaded from the hub when the call fob is powered up.

The selection of the call fob features is by hub configuration. All call fobs are physically identical and support the same features (if enabled at the hub).

An LED, buzzer and vibrate motor are contained within the call fob and are used to indicate the call status. These change when a call is accepted by a remote user using the hub or a pager. Indication of 'assistance on its way' is signalled in this way.

An AAA size battery powers the call fob. Either rechargeable NiMH or disposable alkaline batteries may be used. Note that rechargeable batteries cannot be charged in the call fob; the battery will have to be removed and placed in an external charger when charging is required.

For more information see 9621-8277 EkoTek Call Fob User Guide.

Pager

The pager has the following key functions:



- Display of and response to assistance calls from other EkoTek devices
- Display of paging messages created using the hub's web server or an external system
- Raising assistance calls in a similar manner to the call fob
- Snatch cord operation (later models only)

For more information see 9621-8275 EkoTek Pager User Guide.

EkoTek's 2-way radio network provides message interchange between devices. For example, when a call fob raises an assistance message, this is displayed on pagers and the hub. A pager or hub user can then accept the call, which is then signalled back to the call fob and indicated to the user by a change in the LED and beep pattern being emitted by the call fob during the assistance call.

Paging messages can be generated either via the hub web server or an external system. Web server-originated pager messages can be configured to show delivery and request a 'Yes/No' response. With this two-way paging function, simple task management systems can be easily created.

In a similar way to call fobs, pagers are able to generate assistance calls using the red assistance button on the pager, the inbuilt man down or dead man functions, or location alarms. A pager can therefore function as both an alarm unit and a display, eliminating the need for users to carry both types of unit.

An AAA size battery powers the pager. Either rechargeable NiMH or disposable alkaline batteries may be used. Charging contacts on the pager are used when the pager is inserted into a charging rack.

Later pager models also have a snatch cord that is inserted into a socket on the body of the pager. The pager generates personal security assistance calls when the snatch cord is pulled and disconnected from the body of the pager. On these models the snatch cord can be replaced with a blanking plug if this functionality is not required.

Quad pager charging rack



The Quad Pager Charging Rack charges up to 4 pagers at one time in the rack, with a maximum charge time of 12 hours to charge a pager battery to 50% of its capacity.

The pager reports charging in its usual status report. An extra report is generated when a pager enters or leaves the charger so the hub can update its status quickly.

When a pager reports its battery status as charging, this is shown on the device status display.

Man down and dead man alarms are automatically disabled when a pager is inserted into the charging rack.

When a pager is installed in a charging rack, a user-configurable feature allows the pager to be set to receive or ignore messages, allowing the pager to continue to function in the charging rack if required.

The standard EkoTek PSU is used as the rack PSU and can be used to power up to two charging racks

Note: The pager must be fitted with a NiMH rechargeable cell when used in a charging rack. Use of the charging rack with other types of cell may damage the pager.

Network design and survey

Overview

The survey is used to assess the number of repeaters required and best locations. It is suggested that the surveyor reads the 'System overview' section (page 5) to become familiar with the basic principles of operation.

Prerequisites

- Two survey units
- Site plan

Placement rules

Each repeater connects to the hub, either directly or via another repeater. The number of repeaters required depends on the size and layout of the building and the consistency of the radio coverage.

The EkoTek hub and repeaters must not be installed in areas where explosive gas or dust products may be present. Devices must be protected from liquids, extreme temperatures and strong magnetic fields. Do not install in places where they will be exposed to strong sunlight or electromagnetic interference.

Hub

The hub should be placed in an area such as a control room or reception desk where it is possible to monitor the display when required. Other considerations are to minimise the number of hops required for any repeater to connect to the hub; it is better if possible that the hub be located at the centre of the network. The hub must be located near an AC mains socket outlet and an Ethernet connection if required; it should also be borne in mind that connection via a modem link to the telephone network may be needed, so access to a telephone socket would also be necessary.

Repeaters

Ideally repeaters should be spaced 10-15 metres apart. They should be no closer together than 6 metres, except where there is a structural barrier such as a wall between repeaters sufficient to attenuate the radio signal. The maximum range is 20 metres, but placing repeaters at this distance should be avoided if possible, as any degradation of the radio path may result in the loss of connection between repeaters.

For the positioning of a solar repeater see 'Solar repeater positioning' (page 26).

Multi-storey buildings

EkoTek can be used in multi-storey buildings, provided that the floors are of concrete construction. The concrete floor provides sufficient attenuation of the radio signal to ensure that the pager or call fob's location is reported on the correct

floor. In wooden floored buildings, the pager may pick up a beacon from the floor above or below, giving an inaccurate location for the device.

In order to establish which floor the pager or call fob is on, it is important that repeaters are placed at the entrances to the bottom and top of stairwells. The actual placement of the repeater may not necessarily be in the stairwell itself, but may be in a room leading to the stairwell, in order to provide sufficient radio separation between repeaters.

Corridors

In long corridors it may be prudent to place a repeater in the middle of the corridor as well as at the ends, to ensure robust radio connection in the mesh.

Room placements

If locating individual rooms, place the repeater as central to the room as convenient. Placing it on the edge of the room may allow a sufficient strength of location signal to pass through the wall, to be seen as a beacon by a pager or call fob in the adjacent room.

It is however highly unlikely that the signal would pass through more than one wall.

In large rooms such as warehouses, it may be necessary to place more than one repeater to ensure adequate radio coverage.

Between buildings

If buildings are sufficiently close together, radio signals may pass between them. However, if for example a vehicle passes between the buildings, it may cause signal deterioration and the repeater to lose contact with its parent. For this reason on a multi-storey building, it would be better to force the repeaters on the first floor to form the link between buildings. This is achieved by setting the downstream link of the parent on the first floor of one building to be a specific channel and the upstream link of the repeater on the first floor of the adjacent building to be also the same channel.

Mesh structure

A repeater can only have one parent at a time; however, the principle of a mesh network is that if a connection fails the repeater can search for an alternative parent in order to rejoin the network. If it is unable to locate a suitable new parent, its portion of the network will be broken. It is therefore important to ensure that any repeater has multiple potential paths to the hub.

The survey unit

The survey unit is designed to assist in the placement of repeaters and trouble - shooting the network. It has several modes of operation, described below. The ▲ ▼ buttons scroll through the menus. A long press on the ► button will switch the survey pager on and off.

When taking measurements always hold the pager by the left hand side to avoid masking the signal; the pager's antenna is located on the right hand side. Also avoid placing your body between the pager and the measured device, as this will attenuate the signal.

Note: The survey pager is continuously transmitting a signal and its battery life is therefore short. To avoid unnecessarily draining the battery, remove it when not in use.

Survey pager modes

RSSI

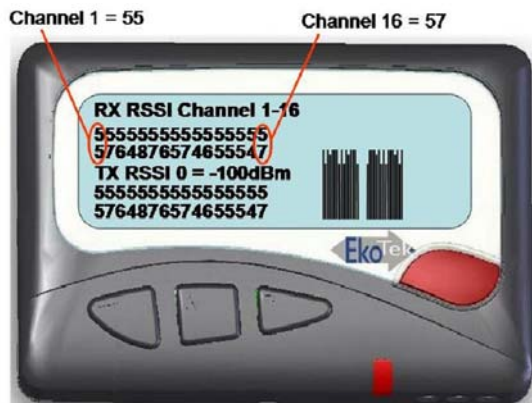

This screen indicates the signal strength for each channel in both the Rx and Tx paths. The measurement for each channel is displayed as a vertically stacked number. Ideally the RSSI should be 15 or above.

Quality

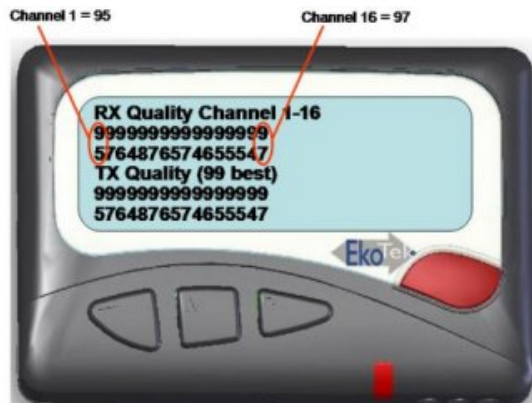

This screen indicates the quality for each channel in both the RX and TX paths. The measurement for each channel is displayed as a vertically stacked number. The range of reported values is 0 to 99 with 99 being the best quality. Ideally the quality should be 85 or above.

Network monitoring mode

Channel activity

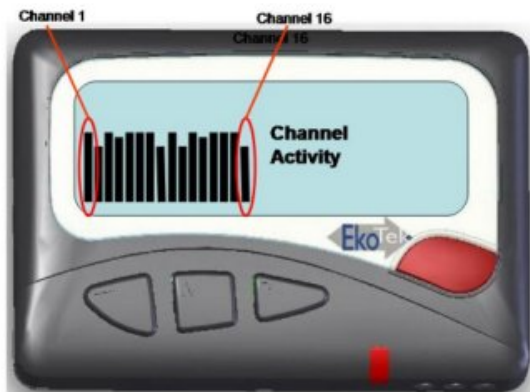

This shows the activity on each channel and is useful in determining the amount of Wi-Fi activity on the system. Note: Channel activity can take some time to be detected, so run for at least one minute.

Repeater information

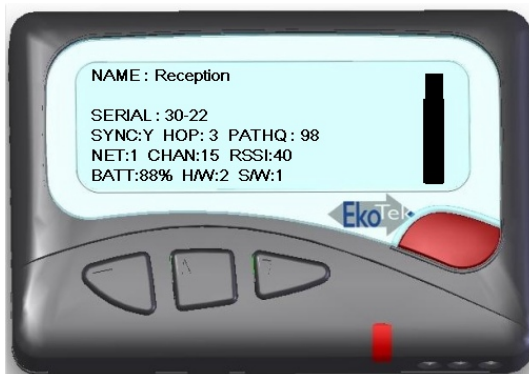

This screen shows information about the repeater that the survey pager is connected to. The bar display shows the strength of the repeater's beacon received by the survey pager relative to the programmed repeater location range. The RSSI number is an indication of the signal strength of the repeater's parent as received at the repeater.

Out of range location beacon

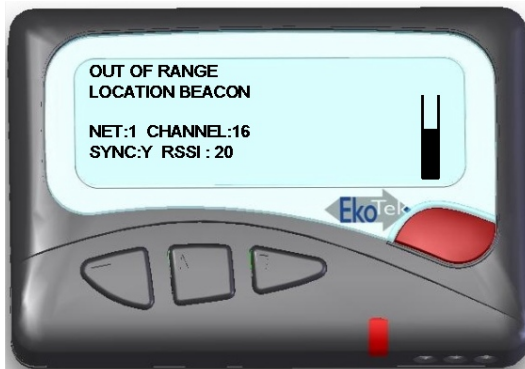

This screen displays information about nearby repeaters. The bar display shows the strength relative to the programmed repeater location range.

How to survey

Decide on the location for the hub. It is desirable to mount a repeater close to the hub location since radio transmissions can be affected by people close by.

Ask the customer which locations are critical for accurate call location reporting and mark on the plan those places as locations for repeaters. It may be every room, a defined area or different floors. In very large rooms consider the use of more than one repeater.

Also mark on the plan the positions for repeaters at the top and bottom of all stairwells, to allow location tracking between floors.

The customer may also want to have a location change when persons leave a critical area. If so, mark repeaters on the site plan at the exit of those critical areas.

When all the likely places for repeaters have been marked, inspect the site plan to estimate if the distance between repeaters exceeds the 10-15 metre maximum separation rule. If there appears to be a long gap between repeaters, consider if there are repeaters on the floor above or below that can form a path for the network.

If a repeater appears to be isolated, use survey pagers to check the RSSI. Place a pager at the repeater and measure the RSSI at its nearest neighbour. Remember its nearest neighbour may be on a different floor. If the nearest neighbour is the other side of a thick wall, other marked locations may provide a more viable route. If in doubt it is best to place in-fill repeaters, as the more repeaters in a network the more robust the network is liable to be. If the RSSI is below 20, then consider placing another repeater in between.

Installation

Preparation

Prerequisites

Prior to installation, the following items are needed:

- Site plan with the position of the hub and all the repeaters clearly marked.
- An AC mains socket outlet for the hub.
- An Ethernet connection to the LAN or dedicated PC.
- A working telephone line and AC mains socket for the PPP connection, if required.
- A line for external ESPA or TAP system connection, if required.

Tools recommended

- Pozidriv screwdriver.
- Screwdriver with 2.5mm blade.
- Stepladder.
- Cordless drill.
- 5mm masonry bit.
- 6mm masonry bit.
- Metric rule.
- Laptop with Ethernet port.
- Ethernet patch cable.
- Call fob and pager.
- It may also be useful to have a survey unit.

Parts required

- EkoTek hub with AC supply unit.
- If modem access to a telephone link is required then use a US robotics 5630D modem with AC supply unit and a RS232 (proprietary) connecting lead. See Appendix 3: RS232 cable pin-outs for connecting the modem to the hub.
- EkoTek repeaters: quantity as required by survey. It is also suggested that a spare repeater is supplied, in case there is a need for infill that was not detected on the survey.

Installing the hub and IP slave hub



The hub can be freestanding on a desk, or wall mounted using the screws provided.

To remove the cover, depress the two protruding plastic tabs and separate the top from the back plate.

Wall mounting

Mark the position of the screws on the wall. The two screws should be spaced precisely 120mm apart, as shown in the diagram of the back plate below:

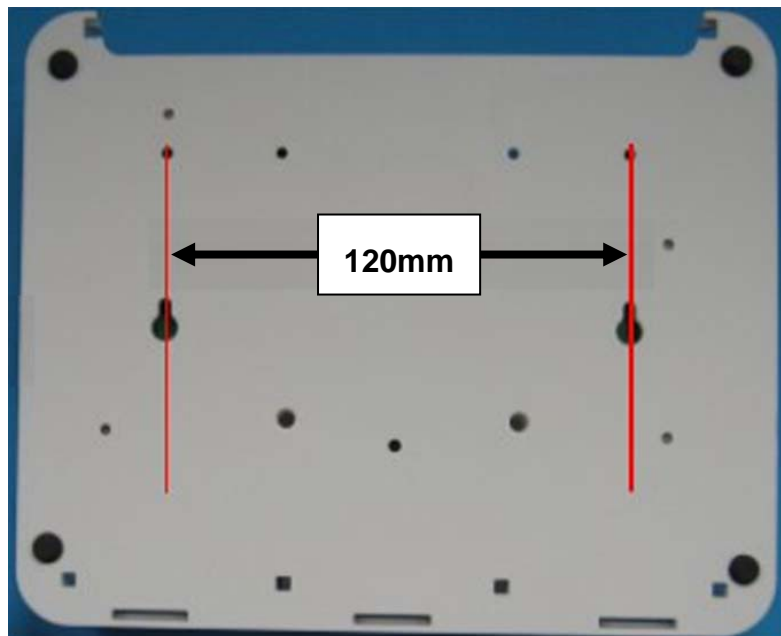

Drill two holes with a 5mm masonry bit to a depth of 25mm.

Insert the wall plugs and screw the screws. Leave 7mm of the screw protruding. (Note: Screws and plugs not provided)

Locate the screw heads in the holes in the back-plate and pull the unit down to lock into place.

Interface connections

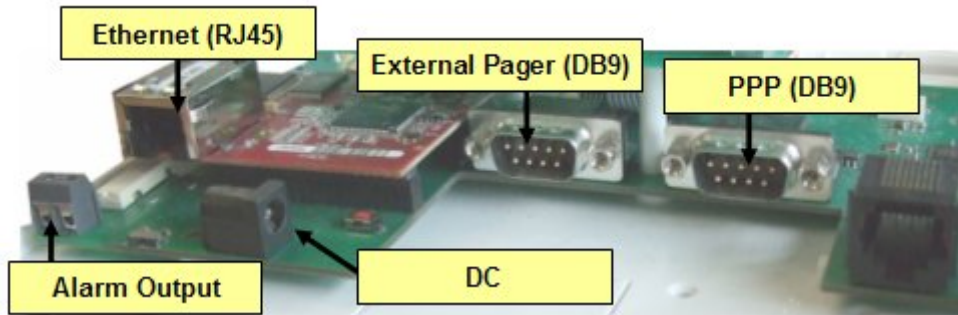

Plug in the AC to DC power adapter

Plug in the Ethernet patch lead to connect to the LAN or PC. See also 'Connecting the hub to the PC using Windows XP' (page 35).

If an external alarm is to be activated from the hub, connect a pair of wires from the alarm output shown in the interface connections diagram. The alarm output is a simple make contact and can be used to operate a customer provided alarm relay. This is not designed to provide a direct contact for AC mains operated equipment.

Connect the DB9 external system connection to the customer's paging system if required. The connection cable should be as specified by the paging system.

A PPP connection can be made after the modem has been set up. See 'Installing the PPP modem' (page 28) for further details.

Installing the repeater, mains powered repeater and call point



Mounting the repeater, mains powered repeater or call point

Remove the back plate from the repeater, mains powered repeater or call point by removing screw A and sliding the top and the base in opposite directions as shown by the green arrows. The standard repeater is shown in the diagram; the call point and mains powered repeater are mounted in the same way.

When mounting the mains powered repeater it may be easiest to detach the power cable from the repeater circuit board first by gently pulling out the connector from the board. The mains powered repeater may be supplied with the power cable already detached.

Use the back plate to mark the position of the screw holes on the wall or ceiling. The call point may be mounted at desk height but if it is also to be used as a repeater it should be mounted using the same criteria as a normal repeater. The contact for the call point should then be extended to a switch (such as a ceiling pull switch).

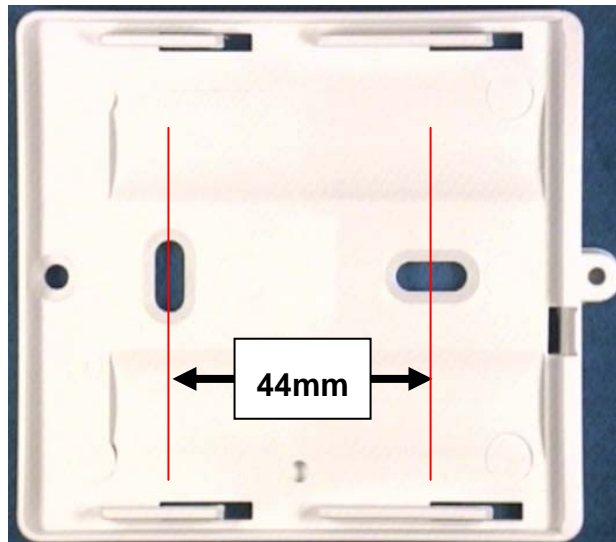

If fixing to masonry, drill two holes with a 6mm masonry bit to a minimum depth of 30mm and insert wall plugs.

Screw the back plate in position.

When installing a mains powered repeater, refer to 'Wiring the mains powered repeater'.

If installing a call point that needs to be wired to an external switch, refer to 'Wiring the call point to an external switch'.

After installation, lock the repeater, mains powered repeater or call point (if required) by screwing the small screw provided in the installation parts, as indicated by A in the picture.

Wiring the mains powered repeater

Note: the mains powered repeater requires a DC supply between 9.5V and 15V at 15mA. When wiring several repeaters in a chain it is important to specify the system power supply and cabling so that the power supply voltage at the repeaters at the beginning and end of the chain are within these limits, taking into account cable resistance. It is advisable to check these voltages with a meter after installation has been completed.

Create an exit point for the wires from the mains powered repeater by removing the section indicated in the illustration below with a pair of pliers.



Turn on the mains powered repeater by removing the link from the repeater PCB. Wire the supply leads to the repeater using the screw terminals in the connecting block. NOTE: this supply must be low voltage DC 9.5-15V. Be careful to observe the correct polarity as shown on the label.

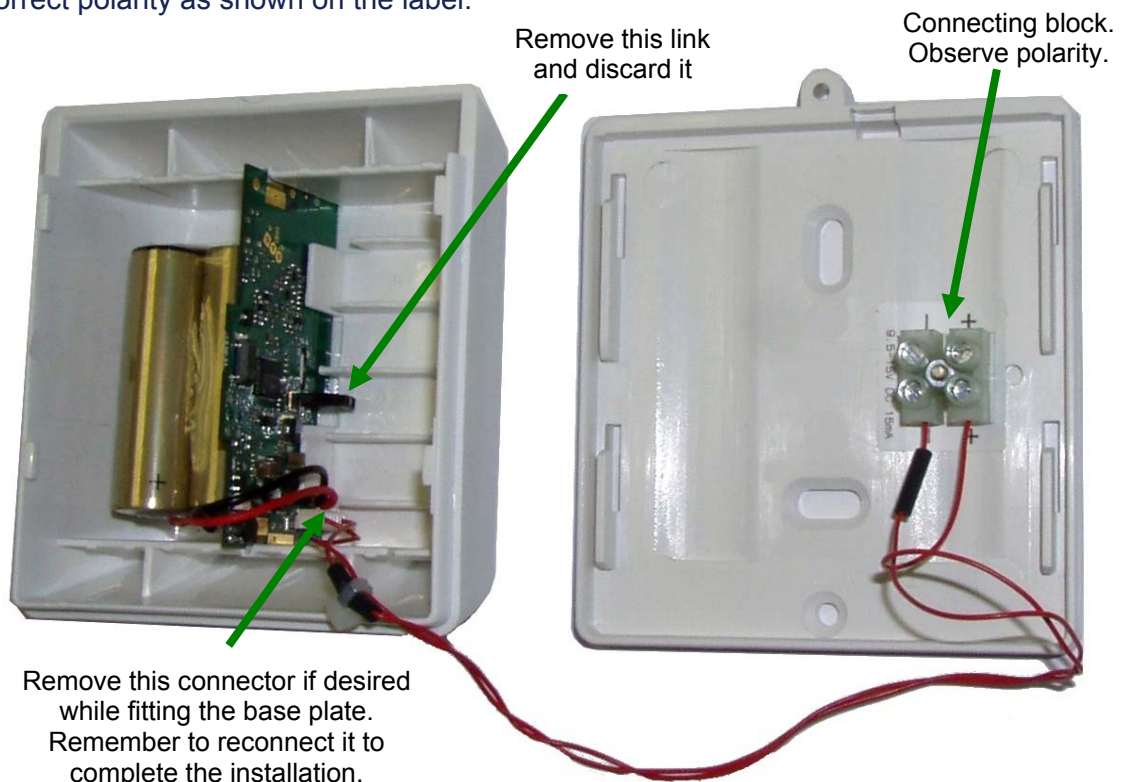

Before sliding the mains powered repeater back on to the base plate, offer the repeater up to the base plate and plug the power connector into the repeater

circuit board. Ensure the batteries are in place then slide the repeater on to the base plate. Take care not to snag the power cable.

Wiring the call point to an external switch

The call point may be wired to an external switch if alarms are to be initiated from a location that is remote from the call point.

Create an exit point for the wires from the call point to the external switch by removing the section indicated in the illustration below with a pair of pliers.



A pre-wired header is provided with the call point and this should be attached paying particular attention to forming the wires as shown below to avoid snagging them when sliding the unit on to the back plate.

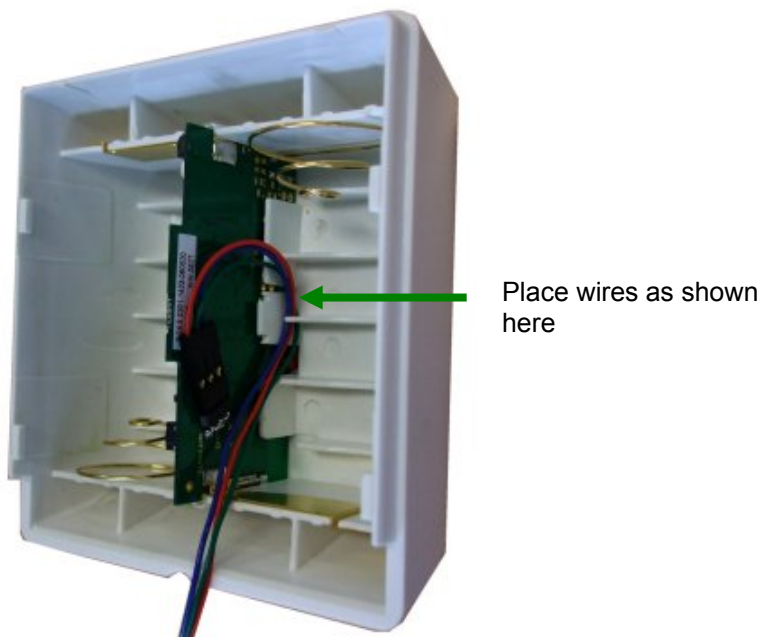

The header is wired as follows:

Pin 1 = External alarm activate.

Pin 2 = Ground (for both contacts).

Pin 3 = External alarm cancel. Connecting this input to the ground pin has the same effect as a long press on the front button of the call point, clearing any alarm that the call point has raised.

Installing the solar repeater

Solar repeater positioning

The repeater should generally be sited with the solar panel facing the sun at its zenith. It must have at average of at least 0.5 hours a day of sunlight shining on the solar panel even in the winter months (note that snow and ice covering the repeater for long periods may cause problems). The normal annual maximum and minimum temperatures must be within the range -20°C to +35°C, although brief periods outside this range will probably not result in failure.

Solar insolation (solar radiation received at the earth's surface) maps can be used to help determine an area's suitability. Near the equator, temperature may be more important than hours of sunshine and facing the solar repeater east so that the unit is not in direct sunlight in the hottest part of the day may be best.

The repeater should be sited so that there are no obstructions causing the solar panel to be shielded from the sun at any time during the year. For example, in London, England (latitude 51.5°N) the sun only reaches 15° above the horizon on the shortest day of the year, so the ideal location will be facing south with no obstruction more than 15° above the horizon.

Use of a compass is recommended.

The solar repeater comes with the batteries pre-installed and must be mounted in a vertical position since the unit has been designed to be switched off when lying on its side.

The solar repeater is distributed with two fixing kits, one designed for wall mounting and one designed for pole mounting.

Wall mounting

The solar panel is fixed to a wall using screw fixing brackets that are attached to the repeater as shown below:

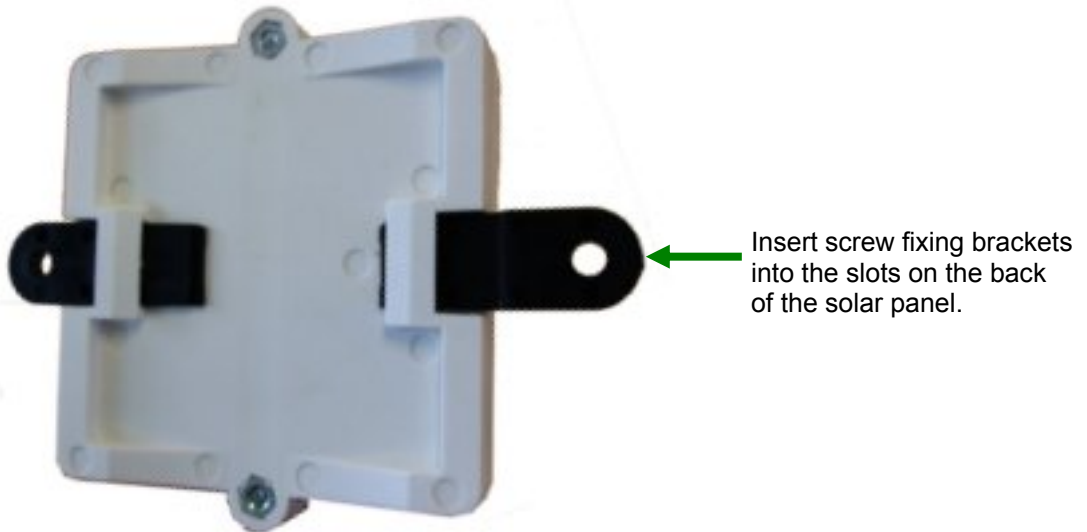

Pole mounting

The solar panel is fixed to the pole using a nylon strap (not provided with the repeater) that passes around the pole and through fixing brackets that are attached to the repeater as shown below:

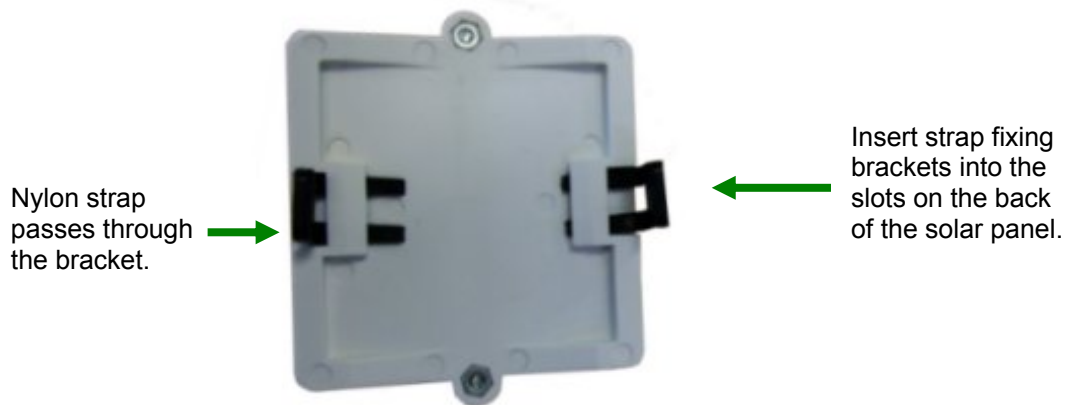

Installing the PPP modem



Connecting the modem

The PPP connection to the hub is made using a US robotics 5630D modem.

1. Plug the modem into the serial port of a PC using the serial interface cable provided with the modem. Use an adapter if the PC does not have a serial port. See Appendix 3: RS232 cable pin-outs for connecting the modem to the hub (page 71) for details of cable pin-outs.
2. Install the US Robotics software onto the PC, from the CD provided with the modem.
3. After installation, locate the software in the programs menu on the PC and start.

The software automatically detects if the modem is connected.

Click the Configuration Manager and go to the Call Control tab



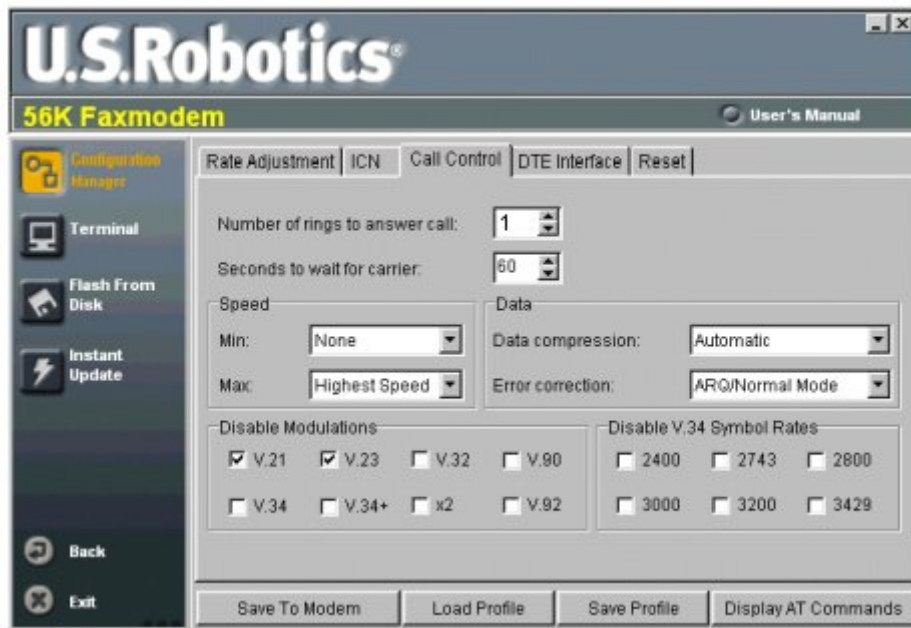

Set the 'Number of rings to answer call' box to 1.

Click the 'Save to Modem' button, which stores the current values from the configuration manager's fields to the writable memory of the modem.

Go to the DTE Interface tab and set the DTR to ignore DTR

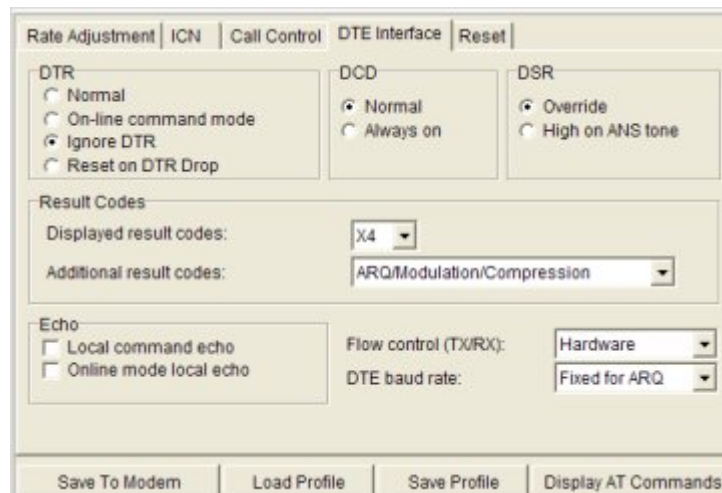

Using Windows Hyper Terminal to set the interface speed

A terminal program is an application that will enable a PC to communicate directly with a modem. If you are using Windows 2000 or Windows XP, you can use the Windows HyperTerminal program as it is included as part of the operating system.

1. Check that the modem is connected to a serial port on the PC.
2. Load HyperTerminal:
 - Click Start > Run

- In the box which appears, type HYPERTERM
- Click OK.

If you see the error message 'Cannot find HYPERTERM' you will need to install HyperTerminal:

- Click Start > Settings > Control Panel > Add / Remove Programs.
 - In Add / Remove Programs select Properties and then click the Windows Setup tab.
 - Double-click Communications
 - Check the box for HyperTerminal
 - Click OK, and then OK again to install.
 - Note: You may be asked for your Windows installation disk for this procedure.
3. When HyperTerminal starts you will be presented with a 'Connection Description' dialogue box.
- Click 'Cancel' to continue.

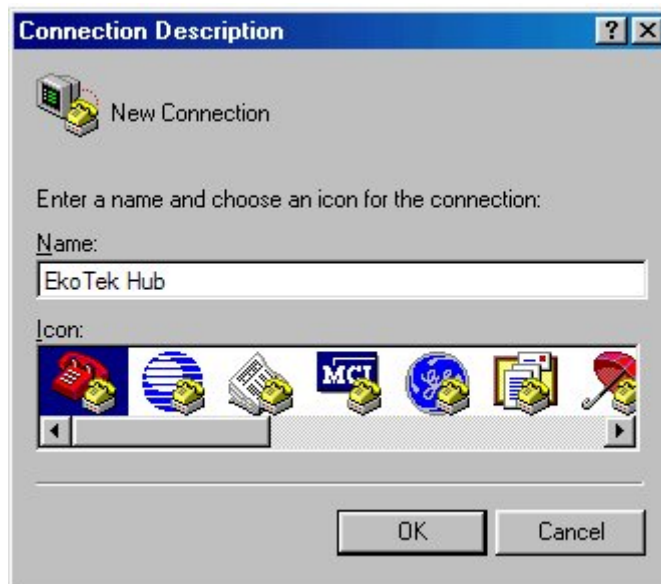

4. Select the preferred COM port:
- Select 'File' then 'Properties' from the menu bar and the 'New Connection Properties' window will open.
 - Click on the arrow for the 'Connect Using' drop down box.
 - Select 'Direct to ComX' (where X is the COM port you are using to connect the modem - e.g. COM1, or COM5, etc).
 - Click OK.

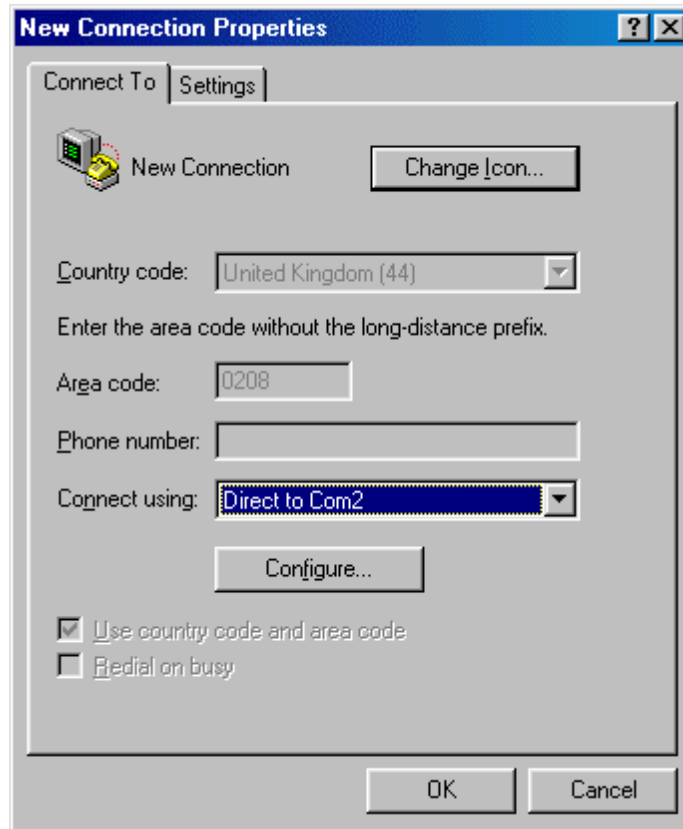

- Configure the port to set the interface speed to 57600.

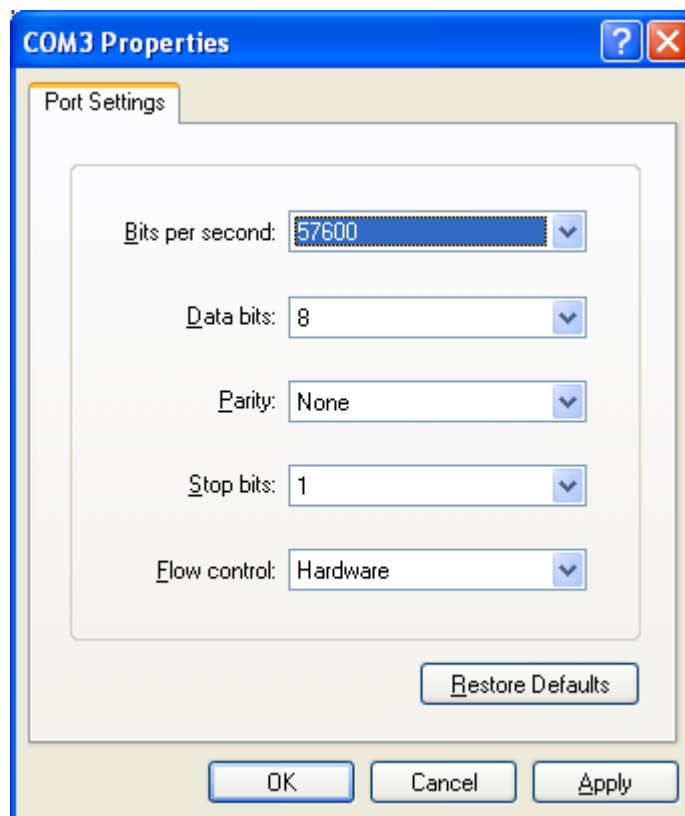

5. Click OK - a blank terminal window will open. You should now be communicating directly between the COM port and modem.
 - Type 'AT' [Enter]

If you are communicating, the modem will reply with 'OK'. If so, proceed to step 6.

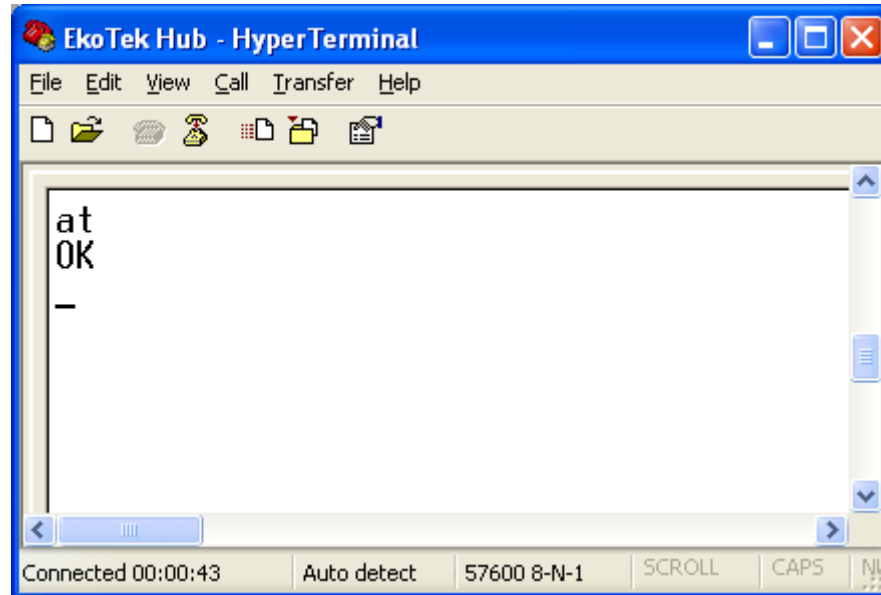

If no 'AT' or 'OK' appears, then there is a basic communication issue between the PC and the modem - most likely the COM port selected is incorrect - check this and try again.

If problems persist:

- Check Windows Device Manager (where available):
 - Check that the modem is installed.
 - Check the COM port is enabled and has no clashes (indicated by a yellow exclamation mark next to it).
 - Check the COM port is enabled in the system BIOS setup.
6. To store the configuration of the port speed in the modem, type 'AT&B2&W' [Enter]. You should receive 'OK' as a response.
 7. Remove the lead from the PC COM port and connect to the PPP socket on the hub.
 8. Close the cover on the hub. Ensure that the ribbon for the keypad is connected to the header on the daughter board, as this is sometimes dislodged when the cover is removed.
 9. Test by dialling in to the modem from a PC. The user name and passwords are both 'EkoTek'. The modem should auto answer and the EkoTek menu screen should be displayed.

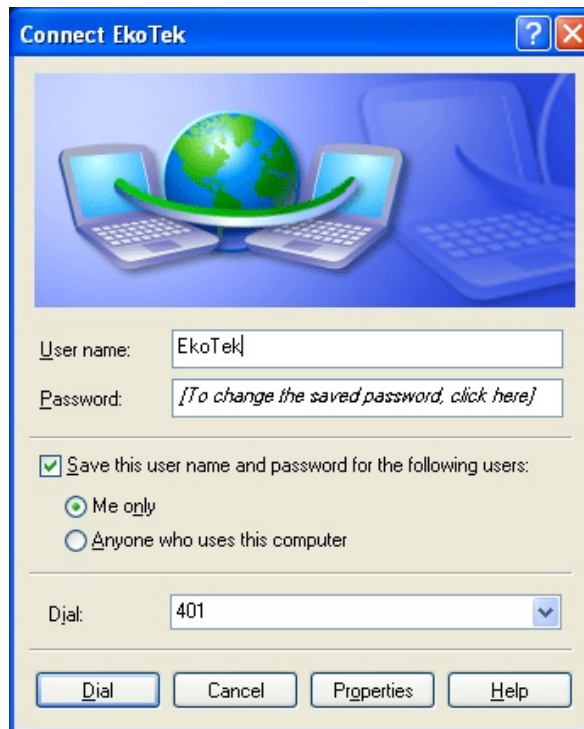

Set up system configuration using the browser as described in the ' Browser interface section.

Installing the 4 way pager charging rack

Up to two 4 way charging racks may be supplied from the PSU.

Wall mounting

Measure and drill the wall according to the diagram:below

If two units are used, join together using the nylon screws and nuts provided as shown below:

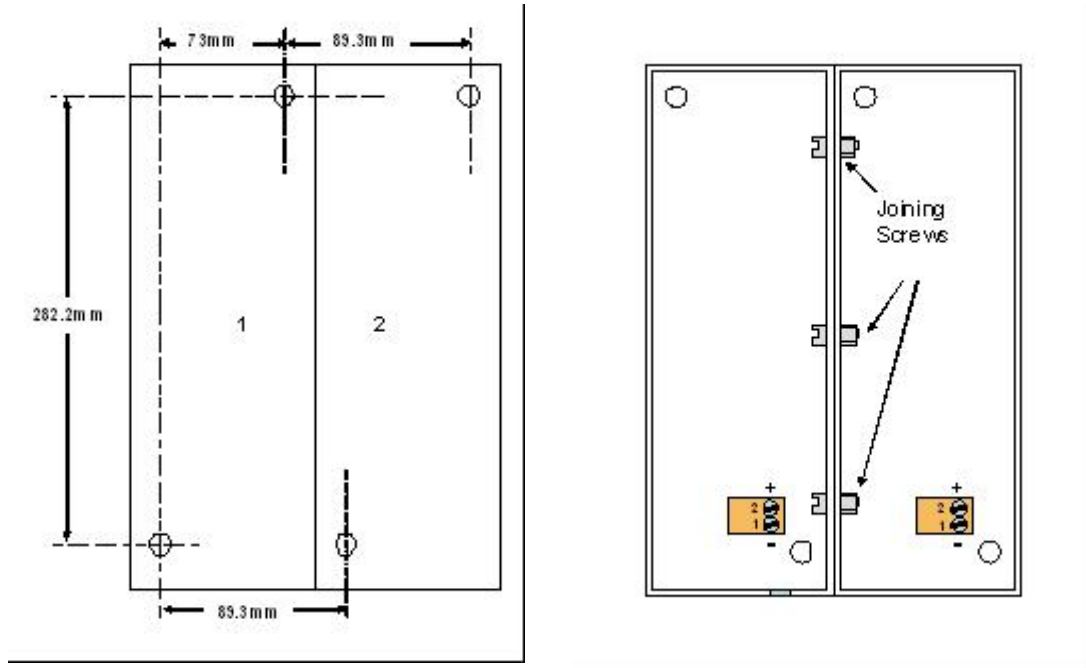

Warning label

Fix the warning label close to the rack where it is easily visible.



IDC connections

Remove or cut off the power jack from the end of the PSU lead. Bare the ends and connect to the IDC connector in the first rack. Ensure the polarity is correct, (+ve black with the white stripe) as shown in the diagram above. Loop the supply through to the second rack if fitted, and terminate as shown in the diagram below.

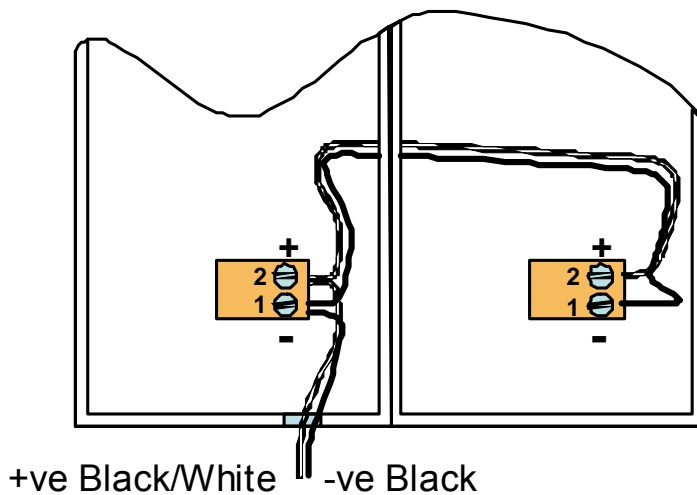

Browser interface setup

Initial setup

In order to configure the system a PC or a network Ethernet connection needs to be made to the hub. This connection can also be used to monitor the EkoTek network. Once the connection has been made, then communication with the hub is achieved through a web browser.

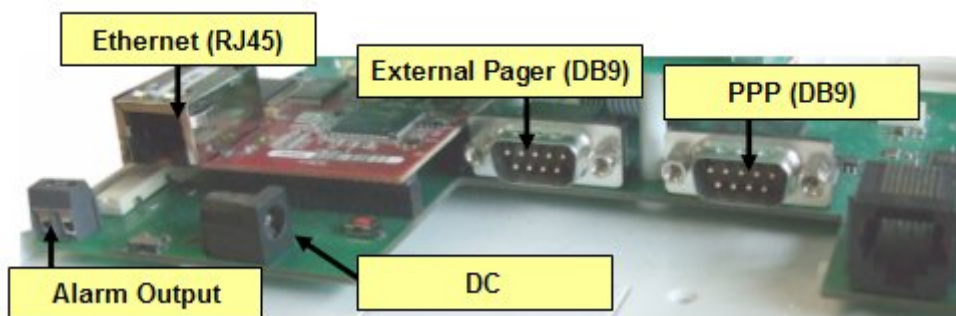

Connecting the hub to the PC using Windows XP

On the PC:

1. Click the Windows start menu and select Control Panel.
2. Click 'Network and Internet connections'.
3. Click 'Network Connections'. With the network cable disconnected, the Local Area connection will be shown as unplugged (X).

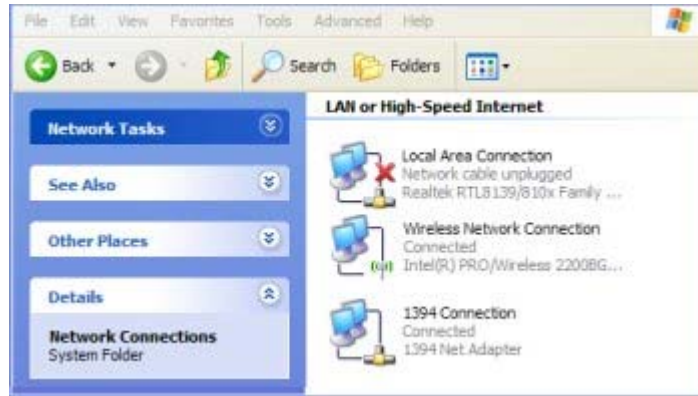

4. Open the hub. To open the hub, push the two locking tabs in and then separate the cover from the back plate.
5. Connect an Ethernet (RJ45) patch cable to the RJ45 connector - see the hub interfaces diagram.
6. Connect the other end of the patch cable to the Ethernet (RJ45) connector on the PC. Note: Some network cards require a crossover cable for direct connection.
7. If connected correctly the screen will change to show the cable connected.

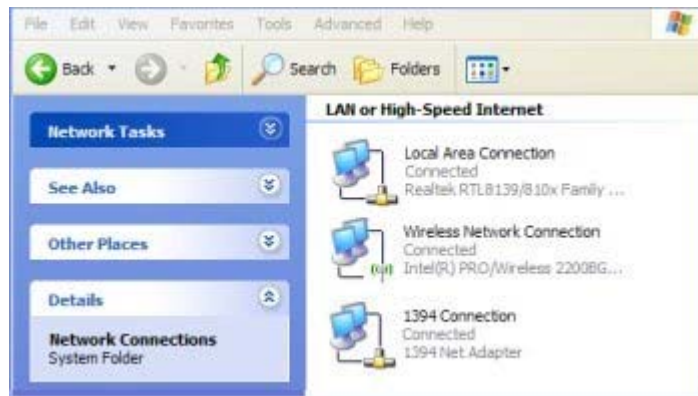

8. Double click the 'Local Area Connection' icon to open the properties window.

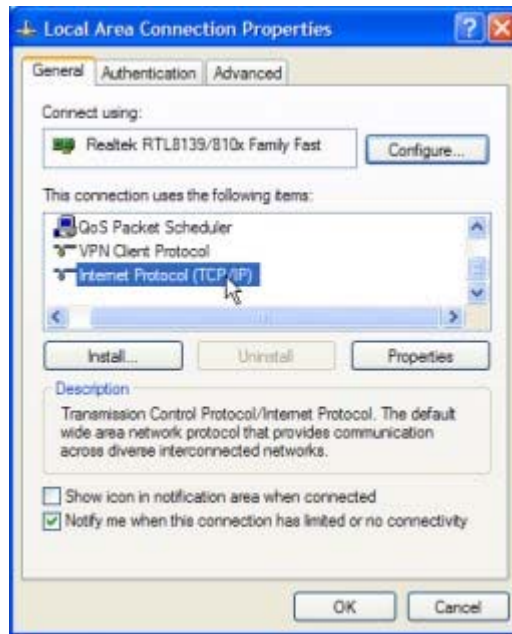

9. Scroll the new window and select the 'Internet Protocol TCP/IP' menu item.
10. Click the 'Properties' button.

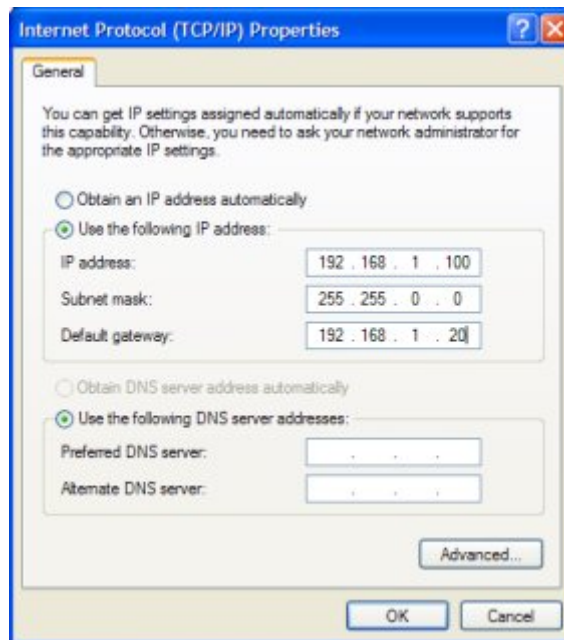

11. The default shipped configuration for the hub is: -
 IP address: 192.168.1.2 (1.1.1.1 if via PPP serial port)
 Subnet mask: 255.255.0.0
 Default gateway: 192.168.1.20

In order to communicate between the PC and the hub, the IP address of the PC has to be set to the same Network and Subnet as the hub. To achieve this select 'Use the following IP address' and enter the IP address in the same range as the hub (in the example above 192.168.1.100 and a subnet mask of 255.255.0.0 Gateway 192.168.1.20).

12. Click 'OK' to finish.

Using the web browser to access the hub

In the address field of the web browser, type the IP address of the hub (default is 192.168.1.2 for Ethernet) and click the refresh button. The browser then connects to the hub web interface.

Password

When a configuration menu item is opened at the beginning of a session, a password is requested. The default is user name 'admin' with no password (blank). Once access is gained the password can be set as required. In addition, user name 'user' (blank password) gives access to 'Main' and 'Maintenance' menu items, and 'Passwords' and 'Browser language selection' under the 'Configuration' menu.



Main menus

Note: the mains powered repeater appears to the system to be identical to a repeater. Wherever a reference to a repeater is seen this also applies equally to the mains powered repeater.

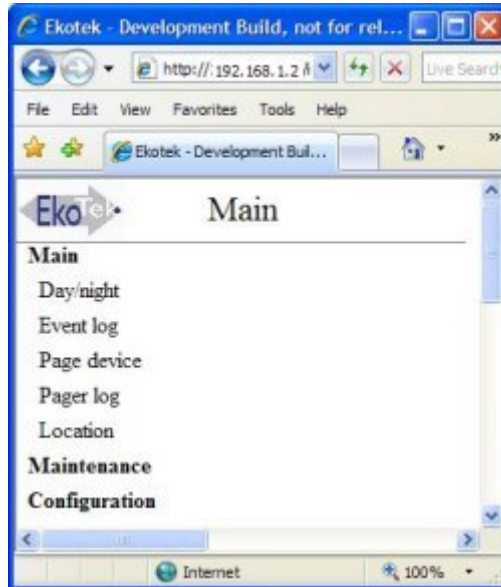

Day/Night

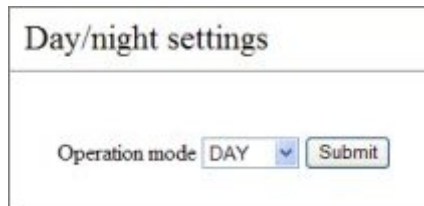
A screenshot of a web form titled "Day/night settings". The form contains a single input field labeled "Operation mode" with a dropdown menu showing "DAY" and a "Submit" button.

Used to set the shift mode. This can be used in conjunction with alert rules to route alarms to different target groups.

Event log

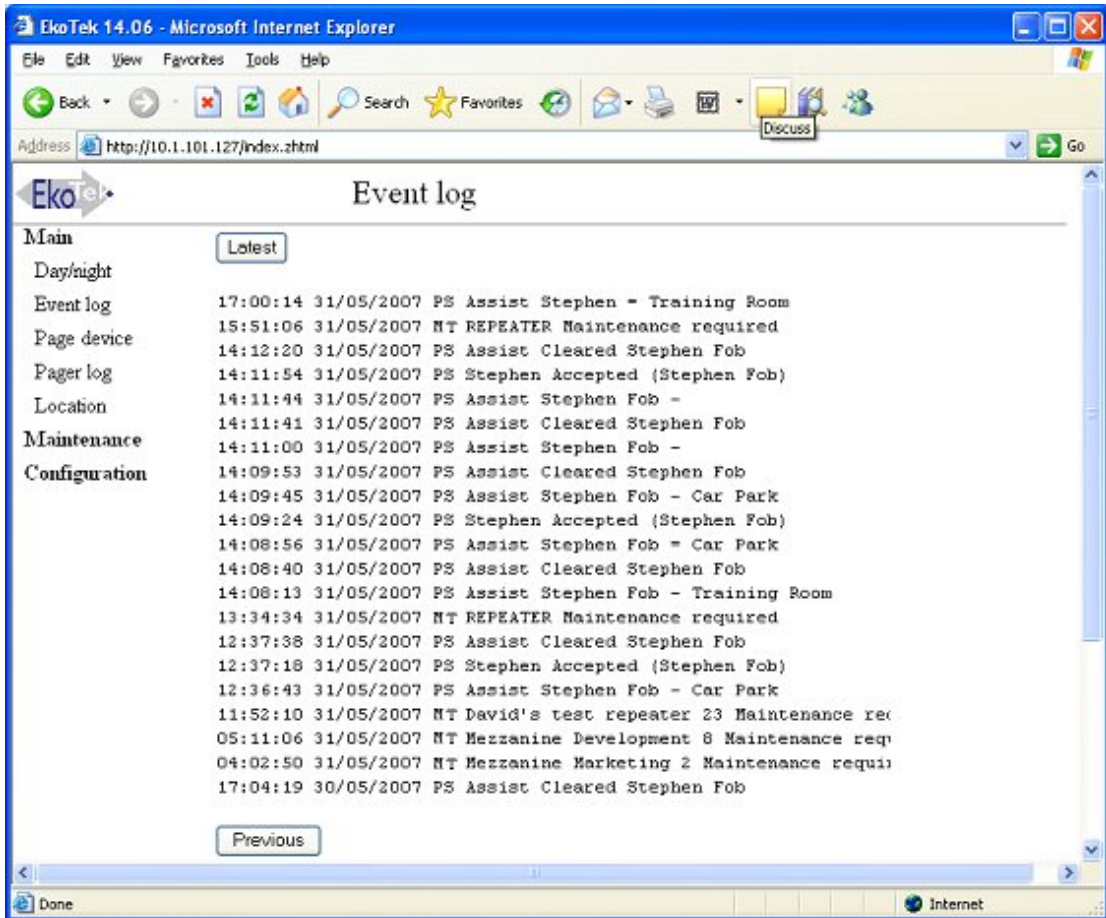

The event log keeps track of all events on the system. It records: -

- The time and date for each event recorded
- The type of event and the text of the associated message.

For each of the applications the following events are recorded.

PS = Personal security: Alarms raised, accepted and cleared

PG = Paging application: Pager messages sent, delivery report if requested, any user responses if requested

MT = Maintenance: Devices not reporting status or low battery warnings

The event log stores the last 9000 events in flash memory. Once 9000 events have been recorded, any new event received is stored and the earliest recorded event is removed from the log.

Page device

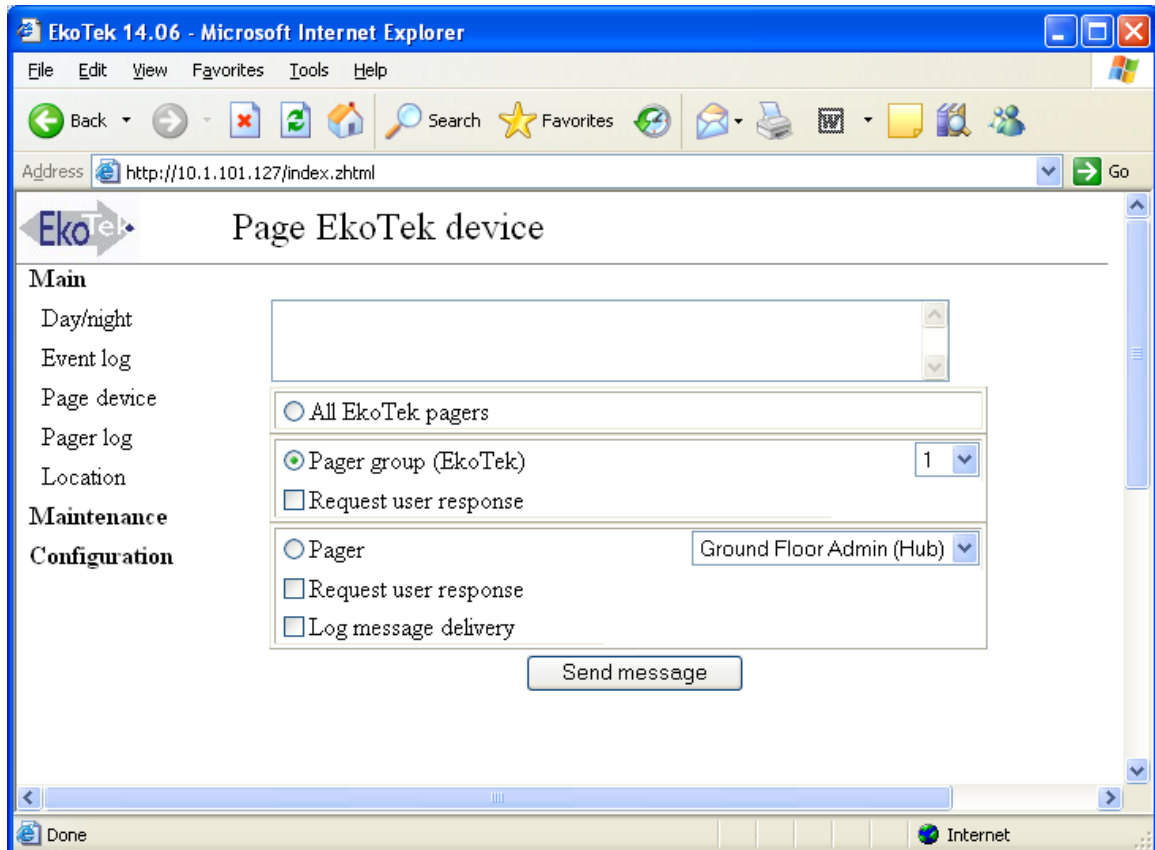

Paging messages can be sent from this screen to all EkoTek pagers, pager groups (select group from drop list) or individual pagers (select pager from drop list). Two-way pager messages for user responses may be requested for pager groups or individual pagers, and delivery of messages to individual pagers may be logged.

Pager log

The pager log stores the last 15 pager messages that had either 'Log message delivery' or 'Request user response' ticked. Messages are kept until the 16th new message with response or delivery request ticked, or if hub is reset.

Note: The pager messages are also written into the event log.

Location

Device location		
Name	Location report time	Location
PAGER	10:16:53 01/01/2000	First Floor
FOB	10:25:15 01/01/2000	First Floor

If location reporting for mobile devices has been enabled under the device mode, the location screen shows the last location reported by each mobile device.

If a device does not have location reporting enabled 'Not enabled' will appear in place of the location report time and location.

If a device has not reported its location since the hub has powered up it will display 'Unknown'.

Maintenance menus

Device status

Device status					
ALL		Refresh			
		Battery level	Last report		
001-0000001	HUB	100%	04:09:49 29/01/2008	Details	
020-0000028	Test Pager	Charging	06:56:56 29/01/2008	Details	
030-0000051	Test Repeater	89%	04:19:14 29/01/2008	Details	
010-0000029	Test Fob	70%	04:13:32 29/01/2008	Details	

Each device in the mesh connects to the hub via a parent device (repeater or directly to the hub itself). Maintaining this connection is important. These statistics relate to that connection. Status reports are made every 4 hr 33 min 4 sec.

Device statuses in the list are highlighted as follows:

Low battery = Yellow

Replace battery = Red

Missed status report = Yellow

Missed four consecutive status reports = Red

Device status - hub and IP slave hub

Device status	
HUB	001-0000001
Name	HUB
Hardware-software	001-137
Last report	10:52:57 07/06/2007
Battery level	100%
Upstream link	Direct connection
Beacon loss count	62
Parent sync loss count	0
Link quality	100
Link strength	100
Upstream traffic	7
Request Update	

Hub: serial number.

Name: name given to the hub.

Hardware-software: revision number.

Last report: time and date stamp of last report.

Battery level: for the hub this will always be 100% when running on mains power. Battery level (%) will be indicated when on backup power.

Upstream link: this will always be 'Direct connection'. It is the topmost link of the network.

Beacon loss count: this records beacons lost since startup or reset.

Parent sync loss: number of times that a loss of sync has occurred since startup or reset.

Link quality: general quality of link to the hub, 1 to 100 where 100=best. Direct connection is always 100.

Link strength: RSSI of parent link, 1 to 100 where 100=best. Direct connection is always 100.

Upstream traffic: count of packets sent to parent.

The loss counts and upstream traffic are simple incrementing counters.

Device status - repeater, solar repeater and call point

Device status	
REPEATER	030-0000082
Name	Ground Floor
Hardware-software	002-137
Last report	22:50:25 03/01/2000
Battery level	90%
Upstream link	REPEATER 030-0000083
Beacon loss count	896
Parent sync loss count	5
Link quality	44
Link strength	100
Upstream traffic	303
<input type="button" value="Request Update"/>	

If no status report has been received these will show

_

Awaiting status report
Unknown

All other fields will be blank.

Repeater, Solar repeater or Call point: serial number.

Battery level: shows the battery level. An alarm is given when battery level drops to 20% and a replace battery message initiated at 5%.

Upstream link: name and serial number of parent repeater or hub.

Beacon loss count: missed parent beacons. This counts the number of times the beacon was expected but not received, either through a faulty parent or degradation of the signal to the parent.

Parent sync loss: number of times that a loss of sync with parent has occurred.

Other fields are the same as for the hub.

Device status - call fob and pager

Device status		Device status	
PAGER	020-0000022	FOB	010-0000001
Name	PAGER	Name	FOB
Hardware-software	001-137	Hardware-software	001-137
Last report	10:16:21 01/01/2000	Last report	10:25:13 01/01/2000
Battery level	72%	Battery level	71%
Beacon loss count	0	Beacon loss count	1
Parent sync loss count	0	Parent sync loss count	0
<input type="button" value="Request Update"/>		<input type="button" value="Request Update"/>	

Pager or Fob: serial number.

Name: name given to device.

Hardware-software: revision number.

Last report: time and date stamp of last report.

Battery level: shows the battery level (%) or 'Charging' if the battery is being charged.

Beacon loss count: missed parent beacons. This counts the number of times the call fob or pager has lost contact with its parent either, through faulty parent or degradation of the signal through moving out of range of the repeaters.

Parent sync loss: number of times that a loss of sync with parent has occurred.

Request update: click to retrieve current statistics.

Configuration menus

System settings - hub

This page sets the network interfaces. It enables configuration of hub settings, clock, external connections and the browser language.

Click 'Configuration' and select 'System'.

Set clock

The clock operates in two modes, one displaying the current time (if JavaScript is enabled on the browser this will update, if not then the clock is a snapshot of the time the page was loaded).

1. Click the details button and enter the current time and date.

2. Click 'Submit' to set.

Note: An illegal clock setting will return to clock display mode, but the original settings will be retained.

Set date format

The hub allows either of two date formats to be selected:

Day/Month/Year – displayed as '16.01.08'

Month/Day/Year – displayed as '01.16.08'

The date format applies to the hub / pager displays and the hub web server pages showing logs, location and maintenance information.



To change the date format click the submit button. This will change the date format to that shown on the button. The button then changes to show the other format. For example, a screen similar to the above will be seen if the date is set to Day/Month/Year format and clicking the 'Submit mm/dd format' button will change the display to Month/Day/Year.

Hub IP configuration

If the hub is to be connected to an Ethernet network the IP address, subnet mask and gateway should be set within the address range of the network, to allow the hub to be accessed from the network. In general the port should be left at the default value unless this port is being used for another application on the network. Once the IP address is configured the hub can only be accessed using that IP address, so a note should be made of any IP address that is set. If the address of a hub is unknown it can be obtained from the front panel. See the EkoTek Hub User Guide 9261-8276 for details.

Note: An illegal IP setting will return to the system settings screen and the original settings will be retained.

Remote system connection

For setting up the connection to an external system, such as a paging or nurse call system. Refer to Appendix 6 for details of remote system configuration.

Remote logging

1. Click 'Remote event logging' to allow system event messages be sent to a remote logging machine.
2. Select 'Numeric', 'Text' or both depending on the required output.
3. Click 'Remote debug logging' to forward all received/transmitted messages to remote machine.
4. Set the IP address of remote logging machine of the remote computer. Click 'Submit' to set the new external connection settings. Logging messages are always sent to UDP port 514.

Note: No check is made that the remote logging machine exists.

For more details of the event logging protocol see Appendix 5: Remote logging protocol (page 78).

Language

The browser interface is available in two versions English ('ENGLISH'), French ('FRANCAIS'), and Spanish ('ESPANOL') or English, French ('FRANCAIS') and German ('DEUTSCH'). Select the required language from the drop list and click 'Submit'.

System settings – IP slave hub

This page sets the network interfaces for the slave hub and the browser language. Click 'Configuration' and select 'System'.

The screenshot shows a web interface titled "Slave settings". It is divided into three main sections:

- Slave:** Contains three rows of IP address fields. The first row is "IP address" with values 10, 1, 101, 141. The second row is "Netmask" with values 255, 255, 0, 0. The third row is "Gateway" with values 10, 1, 100, 254. Below these is a "Submit" button.
- Hub:** Contains two rows of fields. The first row is "IP address" with values 10, 1, 101, 145. The second row is "Port" with the value 6113. Below these is a "Submit" button.
- Browser language:** Contains a dropdown menu currently set to "ENGLISH" and a "Submit" button.

Slave

The IP address, subnet mask and gateway should be set within the address range of the network, to allow the hub to be accessed from the network. Once the IP address is configured, then the slave hub can only be accessed using that IP address, so a note should be made of any IP address that is set. If the address of a hub is unknown it can be obtained from the front panel.

Click 'Submit' to save the slave hub settings.

Hub

IP address: Enter the IP address of the main system hub.

Port: Set the port to that set in the system settings for the main hub.

Click 'Submit' to save the main hub settings.

Radio settings

Radio settings	
Network identifier	<input type="text" value="07"/>
Delay optimisation	<input type="text" value="BALANCED"/>
Frequency hopping	<input type="text" value="OFF"/>
Device auto-register	<input type="text" value="ON"/>
Mobile device monitor	<input type="text" value="OFF"/>
Radio language	<input type="text" value="ENGLISH"/>
Auto-register names	<input type="text" value="HUB"/>

Network identifier

The network identifier enables mobile devices to differentiate between EkoTek systems. Depending on its configuration the mobile device may ignore a different system (if configured to lock to a single network identifier) or attempt to log on to any system. The mobile device will get its configuration from the system it is logged on to. For a mobile device to successfully move between systems it must be able to detect the change, so each system it is to operate on must have a different network identifier. To allow two or more independent overlapping systems to coexist, both systems must have different network identifiers and all mobile devices must be locked on to one of the systems.

Note: Overlapping EkoTek networks are supported from release 3.0 onwards. See Appendix 4: Overlapping system support (page 72) for further details.

Delay optimisation

'Inbound' is used for maximum speed of delivery in the direction towards the hub and is normally only used when there are no pagers on the network, i.e. no outbound user messaging. This is useful if external paging is intended as the main method of alerting users.

'Balanced' is used where there are EkoTek pagers on the system, to give a balanced speed of message flow across the radio network, both towards and from the hub.

'Balanced' is fine for most applications and is the default.

Frequency hopping

The 2.4GHz band has 16 channels. Frequency hopping allows the radio to change frequency (hop) between different channels in the band. This helps the system avoid interference from Wi-Fi devices using the spectrum and offers more security from eavesdropping, if this is a consideration.

The system can also be set to use a fixed frequency.

Usually only the first 14 channels are used for Wi-Fi systems and setting to use a single fixed frequency in channels 15 or 16 could prove to be more robust where there is heavy Wi-Fi usage. Set to 'On' (frequency hopping enabled) or 'Off' as required. By default the hub is configured to the fixed frequency option ('Off').

Device auto-register

If device auto-register is set to 'On', any unknown device that is detected is permitted to join the network provided that the device limits have not been exceeded. These devices will be given default names. If the auto-register is set to 'Off', devices need to be manually added to the database before they will be recognised as on the system.

New devices are set to default to:

Default Name

User Group 1

Fixed Device Zone 1

Device Mode 1

Any devices with a display will be added to the first pager group if capacity exists

Mobile device monitor

All repeaters are automatically monitored for battery condition and presence on the network, with maintenance messages generated on low battery or absence of the device from the network. Mobile devices (pagers and call fobs) can also be monitored for battery condition and presence on the network. Set to 'Off', 'Battery' or 'Network+Battery' as required.

Note: The battery condition will be displayed on the 'Device status' page, regardless of this setting.

Radio language

The pager display language is available in English, French, Spanish or German. Not all languages are available on all hub variants – see 'Language' section (page 46) for details. Select required language from the drop list and click 'Submit'.

Auto-register names

With the device auto-register set to 'On', when the network detects a device it gives a default name appropriate to the device type: HUB, IP SLAVE, REPEATER, SOLAR REPEATER, CALL POINT, PAGER or FOB. This default name can be redefined if required.

Select device from the drop list and click 'Details'. Enter a new name for the default and click 'Submit' to set. For example, this sequence could be used to set all pagers to register by default as 'Staff' and all call fobs as 'Visitor'.

Devices

Overview

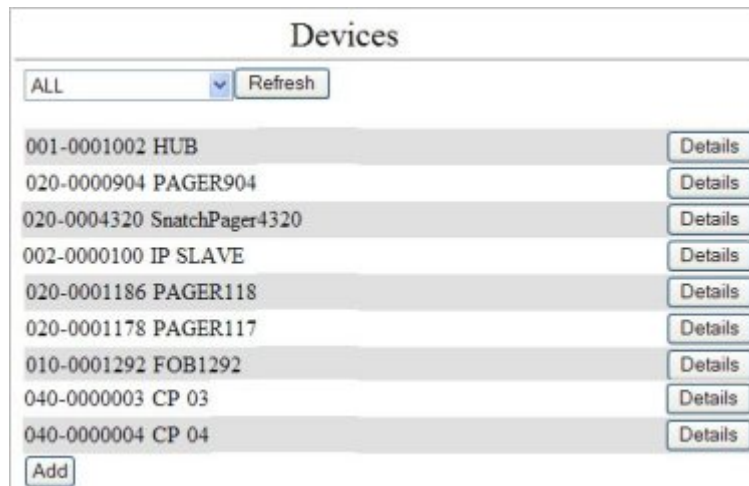

Devices	
ALL	Refresh
001-0001002 HUB	Details
020-0000904 PAGER904	Details
020-0004320 SnatchPager4320	Details
002-0000100 IP SLAVE	Details
020-0001186 PAGER118	Details
020-0001178 PAGER117	Details
010-0001292 FOB1292	Details
040-0000003 CP 03	Details
040-0000004 CP 04	Details
Add	

The overview page lists all the devices connected in the EkoTek network.

Refresh

To get the current list of devices, select the hardware type to be listed from the drop list and click the 'Refresh' button.

The devices will then be listed; the first column gives the hardware type and serial number of the device, the second column gives the device name and the third provides a 'Details' button, to go to that specific device's record.

The serial number of each device is displayed and the device name.

- 001-xxxxxxx indicates a hub
- 002-xxxxxxx indicates a IP slave hub
- 010-xxxxxxx indicates a call fob
- 020-xxxxxxx indicates a pager
- 030-xxxxxxx indicates a repeater
- 031-xxxxxxx indicates a solar repeater
- 040-xxxxxxx indicates a call point

Click the 'Details' button to see the details of any device.

Add

Click 'Add' to go to the 'Add a new device' entry pages.

1. Select device type from menu.
2. Enter serial box and enter the serial number and name. The entry screen below is for a repeater. Similar screens are shown for other device types, with the appropriate hardware code displayed.

The screenshot shows a web form titled "Devices". It contains two input fields: "Serial number" with the value "030-0000043" and "Name" with the value "Security1". Below the "Name" field is a "Submit" button.

3. Click 'Submit' to add the new device. If the entry is valid the individual device entry page will then be displayed. If entry is not possible (invalid serial number length, attempt to add a device prior to the hub, attempt to add a second hub, too many devices already on-system, etc.) then 'Invalid device request' will be displayed. If a device exists in the database with the same serial number as the new requested device, the existing device details will be displayed.

Details

Hub, IP slave hub and call point

The screenshot shows a web form titled "Devices" for a hub configuration. It displays the "HUB" identifier as "001-0000001". Below this, there is a "Name" field containing "HUB", and three dropdown menus for "Device mode", "User group", and "Zone", all set to "1". A "Submit" button is located at the bottom of the form.

Name

The name of the hub or call point may be changed, by entering a new name in the box.

Device mode

The hub or call point is allocated a device mode (1-32), with 1 as default. However, the name for each device mode can be user configured, in which case different options will appear in this menu. The device mode defines the behaviours of all similar devices (radio channel, alarm raising ability, etc). See the 'Device mode' section (page 53).

User group

Select from the drop list, to set 'User Group' (1-16). Used to route alarms to different pager groups.

Zone

Fixed devices are allocated a zone number, allowing alarms from mobile devices to be sent to different pager groups based on the hub or repeater (and therefore zone) that the mobile device is connected to, and for directly raising location alarms. Up to 16 zones are supported by the EkoTek system.

After selecting the device mode parameters, click 'Submit' to enter the changes.

Repeater and solar repeater



The screenshot shows a web form titled "Devices". At the top, it displays "REPEATER" followed by the ID "030-0000082" and a "Remove" button. Below this, there is a "Name" field containing "Ground Floor". Underneath the name field are two dropdown menus: "Device mode" set to "1" and "Zone" set to "1". At the bottom of the form is a "Submit" button.

Name

The name of the repeater may be changed, by entering a new name in the box.

Device mode

Each repeater is allocated a device mode (1-32), with 1 as default. However, the name for each device mode can be user configured, in which case different options will appear in this menu. The device mode defines the behaviours of hubs (radio channel, alarm raising ability, etc). See the 'Device mode' section (page 53).

Zone

Fixed devices are allocated a zone number, allowing alarms from mobile devices to be sent to different pager groups based on the hub or repeater (and therefore zone) that the mobile device is connected to, and for directly raising location alarms. Up to 16 zones are supported by the EkoTek system.

After selecting the device mode parameters, click 'Submit' to enter the changes.

Pager and call fob

Devices	Devices
PAGER 020-0000022 <input type="button" value="Remove"/>	FOB 010-0000001 <input type="button" value="Remove"/>
Name: <input style="width: 90%;" type="text" value="PAGER"/>	Name: <input style="width: 90%;" type="text" value="FOB"/>
Device mode: <input type="button" value="1"/>	Device mode: <input type="button" value="1"/>
User group: <input type="button" value="1"/>	User group: <input type="button" value="1"/>
<input type="button" value="Submit"/>	<input type="button" value="Submit"/>

Name

The name of the pager or call fob may be changed, by entering a new name in the box.

Device mode

Each pager and call fob is allocated a device mode. The device mode defines the alarms and location reporting. See the 'Device mode' section (page 53).

User group

Select from the drop list, to set 'User Group' (1-16). Used to route alarms to different pager groups.

After selecting the device mode parameters, click 'Submit' to enter the changes.

Device mode

Device mode		
HUB	<input type="button" value="1"/>	<input type="button" value="Details"/>
FOB	<input type="button" value="1"/>	<input type="button" value="Details"/>
PAGER	<input type="button" value="1"/>	<input type="button" value="Details"/>
REPEATER	<input type="button" value="1"/>	<input type="button" value="Details"/>
SOLAR REPEATER	<input type="button" value="1"/>	<input type="button" value="Details"/>
CALL POINT	<input type="button" value="1"/>	<input type="button" value="Details"/>

This section allows changes to be made to device parameters. The initial page presents a list of the different hardware types. A drop down menu allows selection of a specific device mode for the hardware type (by default these are 1-32, but they can be renamed) and a 'Details' button, which goes to the specific hardware device mode page.

Device mode – hub and IP slave hub

Device mode

HUB

Channel	<input type="text" value="15"/>		
Location range	<input type="text" value="2"/>		
Manual alarm enable	<input checked="" type="checkbox"/>	Alert text	<input type="text" value="Assist"/>
		Operation	<input type="text" value="Single click"/>
Alarm audible alert	<input checked="" type="checkbox"/>		
Deadman alarm enable	<input type="checkbox"/>	Alert text	<input type="text" value="No response"/>
Timer interval	<input type="text" value="30"/>		(minutes)
User alert period	<input type="text" value="5"/>		(seconds)
Alarm clearance		Alert text	<input type="text" value="Cleared"/>
Alarm escalation period	<input type="text" value="1"/>		(minutes)

The hardware type is followed by the modifiable device mode name (default is 1-32).

Channel

Select from the drop down menu (1 -> 16) to set the radio channel to be used by the hub. The default value of 15 should be used where possible. Different channels should be used for each hub when installing overlapping systems. See Appendix 4: Overlapping system support (page 72).

Location range

Defines the range of the location signal from the hub. The default value is '2' which gives an approximate range in indoor environments of 3 metres. A value of '1' gives the shortest range and '10' the longest range. The range should not be set to high values in deployments where location signal penetration through walls and floors is not desired.

Manual alarm enable

Sets whether the hub can raise manual alarms, i.e. by pressing the button.

Alert text

Modify text to define the message sent to pagers when the alarm is activated. The default text is 'Assist'.

Operation

Define how many button presses are required to trigger the manual alarm (one or two) selected by drop-down menu. Select either 'Single click' or 'Double click'.

Alarm audible alert

Define whether device buzzer sounds when manual alarm is raised.

Dead man alarm enable

Enable the dead man automatic alarm. This is raised if no input is received from the user when prompted by the device.

Alert text

Modify text to define the message sent to pagers when this alarm is activated. The default text is 'No response'.

Timer interval

Sets the time (minutes) between user input prompts.

User alert period

Sets the length of time (seconds) that the buzzer sounds on the hub after the user input prompt before the alarm is raised. If the user presses a button during this time the alarm is not raised.

Alarm clearance alert text

Modifiable text appears in the message sent to pagers when any alarm for this device is cleared. The default text is 'Cleared'.

Alarm escalation period

If an active alarm is not cleared within this period of time (minutes), then the device resends the alarm with an alternate escalation level.

After selecting the above parameters, click 'Submit' to enter the changes.

Device mode – repeater and solar repeater

The device mode entry page shows the hardware type, followed by the modifiable device mode name (defaults 1-32).

Lock to network

With Overlapping System Support (OSS), the repeaters must be locked to a network if there are overlapping systems. To lock to a network check the 'Lock to network' box. It is advised that 'Lock to network' should not be checked for single standalone systems, and should not be checked for an overlapping system until all devices have joined the network. For more details see Appendix 4: Overlapping system support (page 72).

Upstream channel / downstream channel

This applies to repeaters, solar repeaters and call points only. Used to determine the radio channel (1-16) of the repeater, selected via drop down menu. In addition, the 'As parent' setting allows a repeater to use the same radio channel

as its parent device. This is the default mode of operation, allowing for a self-organising radio network.

Location range

Defines the range of the location signal from the repeater. The default value is '2' which gives an approximate range in indoor environments of 3m. A value of '1' gives the shortest range and '10' the longest range. The range should not be set to high values in deployments where location signal penetration through walls and floors is not desired.

After selecting the above parameters, click 'Submit' to enter the changes.

Device mode - call point

The device mode entry page shows the hardware type, followed by the modifiable device mode name (defaults 1-32).

Lock to network, Upstream channel, Downstream channel, Location range

These are set in the same way as for the standard repeater.

Repeater

If this is set, the call point acts as a repeater as well.

Manual alarm enable

Sets whether the hub can raise manual alarms, i.e. by pressing the red button.

Alert text

Modify text to define the message sent to pagers when the alarm is activated. Default text is 'Assist'.

Operation

Define how many button presses are required to trigger the manual alarm (one or two) selected by drop-down menu. Select either 'Single click' or 'Double click'.

Alarm audible alert

If enabled, the device buzzer sounds when manual alarm is raised:

- Single pips – Raising alarm
- Double pips – Raised alarm (the hub has sent out an alarm message)
- Triple pips – Alarm accepted by a pager user.

Contact Input

Alert text

Modify text to define the message sent to pagers when the alarm is activated. The default is 'Red button'.

Operation

This sets the criteria for the operation of the alarm.

- Changeover - pull cords that have a contact that changes state each time the cord is pulled.
- Momentary - pull cords that have a contact that momentarily closes each time the cord is pulled.
- Switched - switch type input e.g. a thermostat.

Alarm escalation enable

If the 'Alarm escalation enable' option is not selected, the call point will raise the alarm only once and the audible alarm indication on the call point will cancel after 30 seconds.

This is useful for non-critical alarms where the hassle of clearing the alarm outweighs the benefits of repeating alarms with escalation.

When the audible alarm indication cancels after 30 seconds a 'Cleared' message is not sent.

When the audible alarm indication ends the alarm can be raised again.

Alarm escalation period

If an active alarm is not cleared within this period of time (minutes), the device resends the alarm with an alternate escalation level.

Device mode - pager and call fob

Device mode		CALL FOB 1	
Lock to network	<input type="checkbox"/>		
Manual alarm enable	<input checked="" type="checkbox"/>	Alert text	Assist
		Operation	Single click
Alarm audible alert	<input checked="" type="checkbox"/>		
Alarm vibrate alert	<input checked="" type="checkbox"/>		
Deadman alarm enable	<input type="checkbox"/>	Alert text	No response
Timer interval			30 (minutes)
User alert period			5 (seconds)
Mandown alarm enable	<input type="checkbox"/>	Alert text	Man over
Tipover trigger period			5 (seconds)
User alert period			5 (seconds)
Location alarm enable	<input type="checkbox"/>	Alert text	Wander
Location audible alert	<input type="checkbox"/>		
Location vibrate alert	<input type="checkbox"/>		
Report in zones			
			1 2 3 4 5 6 7 8 9 10 11 12 13 14 15 16
			<input type="checkbox"/> <input type="checkbox"/> <input type="checkbox"/> <input type="checkbox"/> <input type="checkbox"/> <input type="checkbox"/> <input type="checkbox"/> <input type="checkbox"/> <input type="checkbox"/> <input type="checkbox"/> <input type="checkbox"/> <input type="checkbox"/> <input type="checkbox"/> <input type="checkbox"/> <input type="checkbox"/> <input type="checkbox"/>
Alarm clearance		Alert text	Cleared
Alarm escalation period			1 (minutes)
Enable location reports	<input type="checkbox"/>		
<input type="button" value="Submit"/>			

Device mode		PAGER 1	
Lock to network	<input type="checkbox"/>		
Manual alarm enable	<input checked="" type="checkbox"/>	Alert text	Assist
		Operation	Single click
Alarm audible alert	<input checked="" type="checkbox"/>		
Alarm vibrate alert	<input checked="" type="checkbox"/>		
Deadman alarm enable	<input type="checkbox"/>	Alert text	No response
Timer interval			30 (minutes)
User alert period			5 (seconds)
Mandown alarm enable	<input type="checkbox"/>	Alert text	Man over
Tipover trigger period			5 (seconds)
User alert period			5 (seconds)
Snatch cord enable	<input type="checkbox"/>	Alert text	Snatched
Location alarm enable	<input type="checkbox"/>	Alert text	Wander
Location audible alert	<input type="checkbox"/>		
Location vibrate alert	<input type="checkbox"/>		
Report in zones			
			1 2 3 4 5 6 7 8 9 10 11 12 13 14 15 16
			<input type="checkbox"/> <input type="checkbox"/> <input type="checkbox"/> <input type="checkbox"/> <input type="checkbox"/> <input type="checkbox"/> <input type="checkbox"/> <input type="checkbox"/> <input type="checkbox"/> <input type="checkbox"/> <input type="checkbox"/> <input type="checkbox"/> <input type="checkbox"/> <input type="checkbox"/> <input type="checkbox"/> <input type="checkbox"/>
Alarm clearance		Alert text	Cleared
Alarm escalation period			1 (minutes)
Enable location reports	<input type="checkbox"/>		
<input type="button" value="Submit"/>			

The device mode entry page shows the hardware type, followed by the modifiable device mode name (defaults 1-32). The device mode entry page content for the pager and the call fob are the same except for 'Snatch cord enable' and its corresponding alarm text, which are not present for call fobs.

Lock to network

If the pager or call fob is to be used exclusively on a single network then the 'Lock to network' should be checked. See Appendix 4: Overlapping system support (page 72).

Manual alarm enable

Sets whether the pager or call fob can raise manual alarms, i.e. by pressing the button.

Alert

Modify text to define the message sent to pagers when the alarm is activated. Defaults to 'Assist'.

Operation

Define how many button presses are required to trigger the manual alarm (one or two) selected by drop-down menu. Select either 'Single click' or 'Double click'.

Alarm audible alert

Define whether device buzzer sounds when manual alarm is raised.

Alarm vibrate alert

Defines whether the vibrate motor is activated when a manual alarm is raised.

Dead man alarm enable

Enable the dead man automatic alarm. This is raised if no input is received from the user when prompted by the device.

Alert text

Modify text to define the message sent to pagers when this alarm is activated. The default text is 'No response'.

Timer interval

Sets the time (minutes) between user input prompts.

User alert period

Sets the length of time (seconds) that the buzzer sounds on the hub after the user input prompt before the alarm is raised. If the user presses a button during this time the alarm is not raised.

Man down alarm enable

Enable the tip-over switch automatic alarm. This is raised if the unit has been moved away from an upright position for a defined period of time.

Alert text

Modifiable text appears in the message sent to pagers when this alarm is activated. Default text is 'Man over'.

Tip-over trigger period

Length of time a device must be moved away from upright, until the user warning buzzer sounds (seconds).

User alert period

Length of time that the buzzer sounds on the device, without it being returned to the upright position and the cancel button pressed, before the alarm is raised (seconds).

Snatch cord

For pagers fitted with a snatch cord (later models only).

Snatch cord enable

When enabled, the user will raise an alarm whenever the snatch cord on a pager fitted with this device is removed. The alarm will be automatically cleared when the snatch cord is reattached.

Note: for earlier pager models without the snatch cord option, or where the blanking plug is used instead of the snatch cord, this feature should always be disabled.

Alert text

Modifiable text appears in the message sent to pagers when this alarm is activated. Default text is 'Snatched'.

Location alarm enable

Enable the location-based alarm. This is raised if the unit is moved to an area covered by repeaters assigned to an unauthorised zone. Check the box to enable this feature. Enter the text to be displayed when the alarm is triggered.

Location audible alert / vibrate alert

The mobile device beeper and vibrate functions can be enabled or disabled when the alarm is raised, allowing either covert or normal alarm operation. Check boxes to enable alert.

Report in zones

To select those zones where the alarm is to be raised, check the box associated with that zone. If the pager or call fob enters an unauthorised (checked) zone the location alarm will be raised. The location alarm will be cancelled automatically if the pager or call fob re-enters an authorised (unchecked) zone.

Alarm clearance alert text

Modifiable text appears in the message sent to pagers when any alarm for this device is cleared. The default text is 'Cleared'.

Alarm escalation period

If an active alarm is not cleared within this period of time (minutes), then the device resends the alarm with an alternate escalation level.

After selecting the above parameters, click 'Submit' to enter the changes.

Pager groups

These pages are used to manage hubs and display pagers into groups. Devices may appear in none, one or many pager groups. Each group is restricted to 35 devices.

Pager group selection page



The screenshot shows a web interface for managing pager groups. At the top, the title 'Pager groups' is centered. Below the title, there is a label 'Pager group' followed by a dropdown menu currently displaying 'High Risk'. To the right of the dropdown menu is a button labeled 'Details'.

The list of 32 pager groups is given in a drop-down menu. By default these are named 1-32. Each group can be assigned a name if required, using the pager group entry page.

Click 'Details' to open the pager group entry page and set up a group.

Pager group entry page

Pager groups

[02] Pager group

HUB	<input checked="" type="checkbox"/>
John Smith	<input checked="" type="checkbox"/>
Fred Bloggs	<input checked="" type="checkbox"/>
Security	<input checked="" type="checkbox"/>
Visitor 1	<input type="checkbox"/>
Visitor 2	<input type="checkbox"/>
PAGER	<input type="checkbox"/>
External pager <input type="text" value="12345"/>	<input type="checkbox"/>

Pager group

Enter text for the pager group name.

All the connected display equipped devices are listed (by name) and a checkbox denoting membership to this group. Check the box to add the devices to the group.

External pager

If connection is to be made to an external pager, enter the pager identifier into the number field. This is the identifier sent via the ESPA/TAP output interface. Check the box to add the external pager to the group.

Click 'Submit' to confirm the new pager group membership. If more than 35 devices are selected the changes will not be accepted.

Alert rules

The alert rules determine the target pager group for every alarm. In addition to these instructions some examples are provided in the online help files installed with the EkoTek system.

Alarms are routed according to the user group of the raising device, the location of the device when the alarm is raised (given by the zone of the local repeater), the day-night setting of the system and whether it is an initial alarm or an escalation of an existing alarm.

By default, no rules are defined and all alarms raised on-system will result in messages being sent to display devices (and the external pager number) in the first pager group.

The page operates in a number of modes, displaying the current rules table, allowing new rules to be added and existing rules to be modified and deleted. By default alarms are routed to pager group 1, alert rules allow this to be overridden.

User group																Zone																Time	Esc				
1	2	3	4	5	6	7	8	9	10	11	12	13	14	15	16	1	2	3	4	5	6	7	8	9	10	11	12	13	14	15	16	D	N	R	N		
■																■																					1

Add

If any rules have been entered a table is displayed, the top row of which contains:

User Group

Parameters set in the device entry. Groups 1 to 16.

Zone

Parameters set in the device entry. Zones 1 to 16.

Time

The day or night setting of the system. 'D'=Day, 'N'=Night.

Esc

The escalation level of the alarm. 'R'=Raised, 'N'=Normal.

A black square means that a particular group, zone, time of day or escalation has been included in the rule. The end of the row is a button containing the name of the pager group that is targeted by the rule. If there are more than 16 rules in the table, the header will be repeated after the last rule.

Edit mapping

Clicking the pager group name button at the end of the row causes the page to be reloaded with modifiable rules; the selected rule will appear as a shaded row and in place of the pager group name a 'Remove' button will appear. The checkboxes are preloaded with the current rules settings. Change the rule settings as required and then click 'Submit' to save the amendments.

Note: the EkoTek system can only send one paging message to an external system as a result of an alarm being raised. If a combination of rules is entered that would cause more than one message to be sent to an external system a conflict is detected and the 'Submit' entry will be ignored until the conflict is resolved.

The following can be entered in the editing screen:

User group

Select the user group(s) always routed by this rule.

Zone

Select the zone(s) routed by this rule.

Time of day

Select the day and/or night settings of the shift mode.

Escalation

The escalation level of the alarm. 'R'=Raised, 'N'=Normal

Pager group

Select the target pager group.

EkoTek pagers only

When a rule has the 'EkoTek pagers only' option selected, messages using this rule will not be sent to an external system. Rules with this option set are shown as a shaded row in the alert mapping table, otherwise they are shown in white.

If 'EkoTek pagers only' is checked, a specified alarm event can be routed to multiple pager groups, i.e. duplicate rules may be created allowing multiple pager groups to be sent a message. In this mode external pagers will not be contacted, so there is no conflict checking across alert maps.

Remove

Click the 'Remove' button to remove that rule from the table.

Add

Click the 'Add' button to enter a brand new rule; note that this option will only appear if there are currently fewer than 32 rules.

Alert mapping

Enter new rule details

1 2 3 4 5 6 7 8 9 10 11 12 13 14 15 16

User group

Zone

Time of day Day Night

Escalation Raised Normal

Pager group

EkoTek pagers only

User group																Zone																Time	Esc		
1	2	3	4	5	6	7	8	9	10	11	12	13	14	15	16	1	2	3	4	5	6	7	8	9	10	11	12	13	14	15	16	D	N	R	N
■																			■																
<input type="button" value="Add"/>																																			

Clicking the 'Add' button will present a screen very similar to the edit rule mode; the initial line is 'Enter new rule details' followed by the options and (clear) checkboxes as for the editing screen.

Click 'Submit' to save the amendments. The new entry is checked for conflicts in the same manner as in the editing screen. After a successful submission the Alert Mapping page shows the new rule added to the list.

Alert mapping

User group																Zone																Time	Esc		
1	2	3	4	5	6	7	8	9	10	11	12	13	14	15	16	1	2	3	4	5	6	7	8	9	10	11	12	13	14	15	16	D	N	R	N
■																			■																
■																			■																
■																			■																
<input type="button" value="Add"/>																																			

Example alert mapping table

Alert mapping

User group																Zone																Time	Esc		
1	2	3	4	5	6	7	8	9	10	11	12	13	14	15	16	1	2	3	4	5	6	7	8	9	10	11	12	13	14	15	16	D	N	R	N
■																			■																
■																			■																
■																			■																
<input type="button" value="Add"/>																																			

The above example contains three rules:

The first rule routes all normal level alarms raised by devices with user group 2, in zones 1,2 or 3, with the system running in 'Day' mode to pager group 'Day'

The second rule routes all normal level alarms raised by devices with user group 2, in zones 1,2 or 3, with the system running in 'Night' mode to pager group 'Night'

The third rule routes all escalated alarms raised by devices with user group 2, in zones 1,2 or 3, to pager group 'Staff' (the light grey highlight denotes that only EkoTek pagers will be contacted in the group)

All other alarms will be routed to the first (default) pager group.

Factory reset



Click the 'Factory reset' button to return the network to factory settings (all devices deleted, IP addresses, passwords reset, etc).

Delete all devices

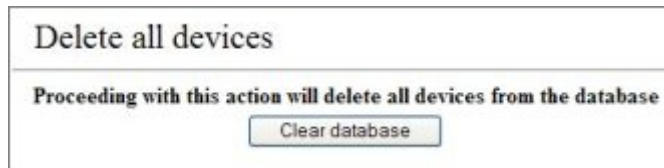

Click the 'Clear database' button to clear the database of all network devices, but leave passwords, IP addresses, etc. as before.

Passwords



Change the system passwords.

'User' followed by a drop-down menu containing:

User

The User level allows access to all pages within the Main and Maintenance menus and to the passwords page under the Configuration menu (it can only change the password for User).

Admin

The Admin level allows access to all functions.

New password

Enter new password in the text input box. Click 'Submit' to enter the new password.

'User/admin password changed' or 'Password change failed' will be displayed, according to the outcome.

A password change failure may also be accompanied by: 'New password must be between 4 and 8 characters long' if the password length is invalid, or 'You do not have permission to change this password' if the user is logged in as User and is attempting to change the Admin password

Archive

This page is used to manage archiving and restoring the system configuration.

Download current configuration to archive file

Click the 'Download' button.

In the 'File download' pop-up box, click save and save the file to a location on the PC.

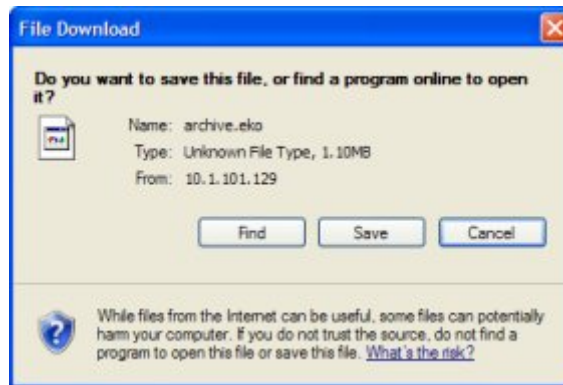

Upload saved archive

Click the 'Browse' button and locate the saved archive.

Click the 'Upload' button and the configuration from the selected file is transferred to the hub. This will take a few minutes. If there is a failure to upload a saved configuration, this will result in the display of the following message: 'Error encountered uploading requested file'.

If a valid configuration has been uploaded to the hub, the following text is displayed: 'Use archive settings (Will cause a hub reset and erase current settings)'. The archived settings will not be applied until the hub is reset.

Click the reset button to change the hub configuration to the archived settings. The process will take a few minutes, and is indicated by the normal separator in the time field on the hub LCD screen being replaced by a flashing exclamation mark. At this stage, trying to navigate within the EkoTek web pages can interrupt the reset irreversibly. To avoid having to begin the upload process again from the start, ensure that you monitor the hub LCD screen: when the normal time separator returns, the process has completed. At this point the web browser can be redirected to the new IP address of the hub.

Final checks

Connect a PC to the hub over the Ethernet connection.

Open the device status in the maintenance menu.

Device status					
ALL		Refresh			
		Battery level	Last report		
001-0000001	HUB	100%	04:09:49	29/01/2008	Details
020-0000028	Test Pager	Charging	06:56:56	29/01/2008	Details
030-0000051	Test Repeater	89%	04:19:14	29/01/2008	Details
010-0000029	Test Fob	70%	04:13:32	29/01/2008	Details

Check that all the repeaters are seen by the hub. If a repeater is not seen it may:

- Be out of reach of a parent
- Be faulty
- Have a flat or disconnected battery.

Investigate the cause using a survey pager. In cases where it is too far from the nearest repeater to get a viable link a repeater may be needed to infill and complete the mesh.

Click the details for each repeater and check the strength and quality of the link. If the link looks marginal, remove the parent of that repeater from the network and see if it will change to a different parent with a better link.

Device status	
REPEATER	030-0000082
Name	Ground Floor
Hardware-software	002-137
Last report	22:50:25 03/01/2000
Battery level	90%
Upstream link	REPEATER 030-0000083
Beacon loss count	896
Parent sync loss count	5
Link quality	44
Link strength	100
Upstream traffic	303
Request Update	

Register a pager and a call fob using auto-register and see if an alarm from the call fob is received at the pager and that the response is sent to the call fob on the network.

This completes the installation.

Appendix 1: Miscellaneous system messages

The following on-system messages are generated in addition to alert texts configured using the web server interface.

Personal security messages

Accepted

Generated as a consequence of a pager accepting a raised alarm.

Pager response messages

Delivered

Accepted

Rejected

Denoting the delivery acknowledgement and appropriate user acceptance or rejection.

Maintenance messages

Low battery

Generated when the battery level drops to 20%, will be re-generated for every further 3% drop until

Replace battery

Generated at 5% battery level and regenerated for every further drop.

Maintenance required

If a fixed device fails to report its status as scheduled on 4 consecutive occasions (each report sent at 4.5 hour intervals) and if the device remains persistently not reporting its status (i.e. a further 6 consecutive missed status reports), a 'Maintenance required' message is generated.

Appendix 2: Specifications

Radio frequency	2405 – 2480MHz
Radio channels	16
Channel operating mode	Fixed frequency, or frequency hopping
Maximum number of radio channels simultaneously used per system	16
Radio power	10mW
Radio coding	CDMA IEEE 802.15.4
Hub power	AC-DC Power Adaptor
Hub backup batteries	3 x C cell NiMH rechargeable batteries
Repeater power	2 x D cell High Capacity Alkaline Manganese batteries
Pager power	1 x AAA cell High Capacity Alkaline Manganese, or NiMH rechargeable battery
Call fob power	1 x AAA cell High Capacity Alkaline Manganese, or NiMH rechargeable battery
Solar repeater power	Proprietary battery pack
Mains powered repeater power	9.5-15V DC 15mA, with proprietary rechargeable battery pack as backup
Charging rack	AC-DC power adaptor
Call point	2 x D cell High Capacity Alkaline Manganese batteries
Maximum number of repeaters per radio channels	90
Maximum number of pagers	127
Maximum number of pagers in a pager group	35
Maximum number of devices per system	500

Appendix 3: RS232 cable pin-outs for connecting the modem to the hub

DB25	DCE	DB9	
2	TXD	3	Transmitted Data
3	RXD	2	Received Data
4	RTS	7	Request to Send
5	CTS	8	Clear to Send
6**	DSR	6	Data Set Ready
7	GND	5	Signal Ground
8	CD	1	Rec. Line Signal Detector

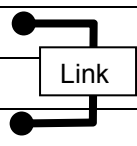

**not connected

Appendix 4: Overlapping system support

Overview

Overlapping System Support (OSS) allows the mesh network radio footprint of multiple hubs to overlap. This may be necessary, for example, where different departments of an organisation have their own independent overlapping EkoTek systems, or where there are fringe radio areas where the networks of multiple hubs overlap.

To provide predictable mesh coverage with OSS, repeaters must be 'locked' to a specific network, ensuring that repeaters form part of the mesh network of the desired hub only. Throughout this section the term 'repeater' also applies to the solar repeater and call point (if the latter is enabled for repeater operation).

Mobile devices may be locked to a specific network or may be allowed to roam between networks at will. The lock/roam setting depends on the requirements of the system design.

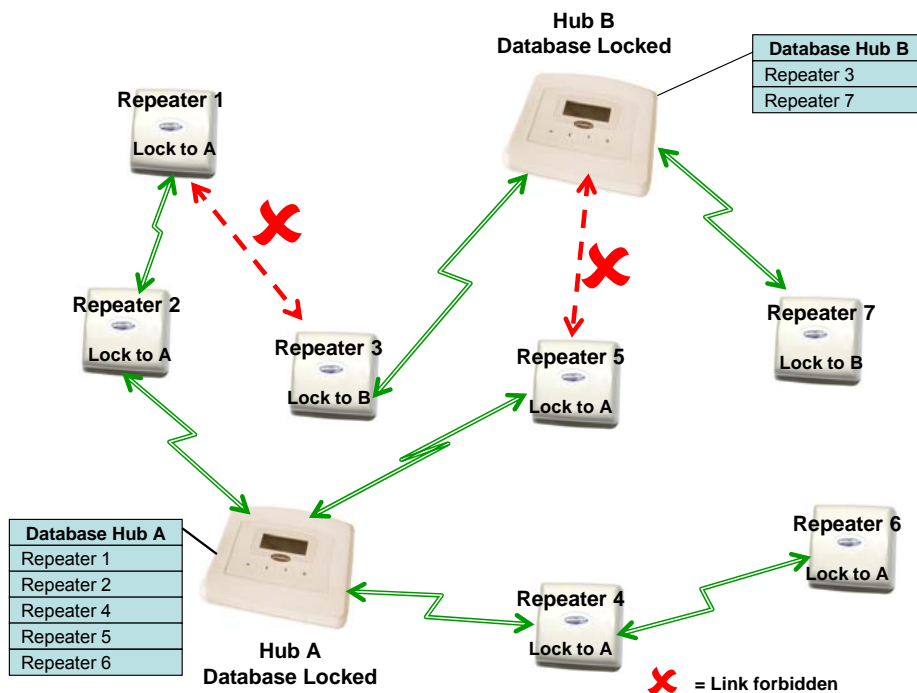

Each network needs to be set with different network identifiers and radio channels. Frequency hopping is forbidden with OSS.

During the network acquisition stage of a device, any networks that reject the device with auto register disabled will be omitted from the parent scan. This will prevent a device from repeatedly attempting to join an unauthorised network. The device will continue to search for other networks.

During network acquisition the device will attempt to join any network it can see. If it is rejected (due to auto-register being disabled) then that network will be ignored for the duration of the network acquisition period. If no valid network has been

discovered after half an hour for mobile devices or six hours for fixed devices, the device will revert to searching for any network.

Overlapping and mobile roaming systems

Two possible configurations for overlapping systems are supported.

- A. Overlapping networks, where two networks substantially overlap at the same location. This could be used to provide exclusive networks within the same area each with its own population of pagers and call fobs.

Overlapping Networks

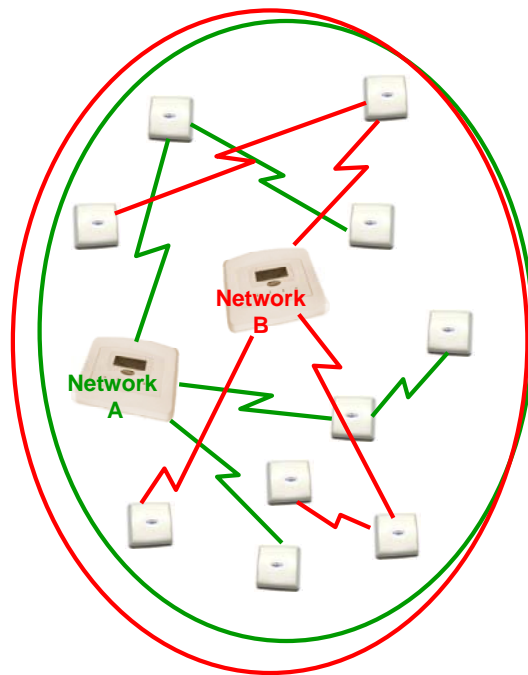

- Repeaters locked to specific hub
- Different channels for each network
- Frequency hopping off
- Auto register off (Database locked)
- Mobiles locked to specific hub
- Different network identities

- B. Mobile Roaming networks, where pagers and call fobs roam between the two networks. In order that pagers and call fobs hand over upon entry to an adjacent network it is important to design the networks to have minimum overlap to give a clear indication of the zone where the pager or call fob is located. This also ensures that pagers and call fobs have time to lose contact with their existing network and join their new network as they move between networks.

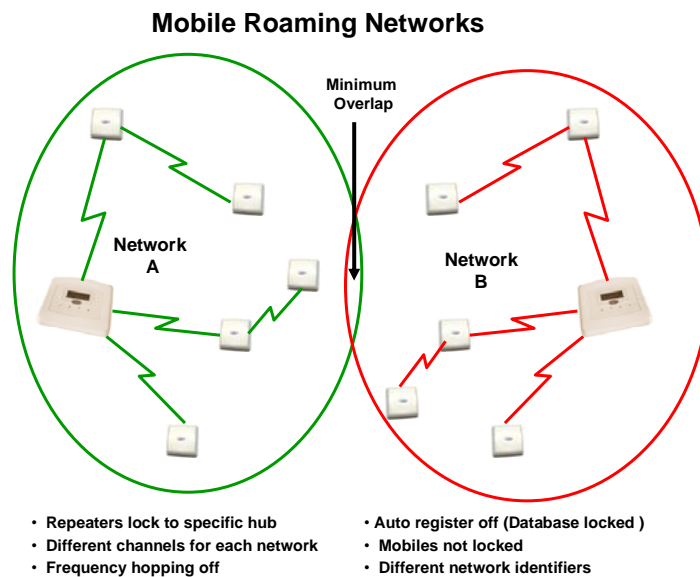

Automatically setting up a multiple hub 'overlapping' system

Network 1

Power up the hub and set as follows:

- Assign a network identifier.
- Select a radio channel for the hub device mode.
- Set 'Frequency hopping' to 'Off'.
- Set 'Device auto register' to 'On'.

Configure the repeaters to lock to this network.

Lock the pagers and call fobs to this network.

Insert batteries into all radio devices for network 1.

Let the repeaters, pagers and call fobs designated for network 1 register with the network.

Set 'Auto register' to 'Off'.

Network 2

Power up the second hub and set it up as follows

- Assign a different network identifier.
- Select a different radio channel for the hub device mode.
- Set 'Frequency hopping' to 'Off'.
- Set 'Device auto register' to 'On'.

Configure repeaters to lock to the network

Lock the pagers and call fobs to the network.

Insert batteries into all radio devices for network 2.

Let the repeaters, pagers and call fobs designated for network 2 register with the hub.

Set 'Auto register' to 'Off'.

Automatically setting up a 'mobile roaming' network

Network 1

Power up the hub and set as follows:

- Assign a network identifier
- Select a radio channel for the hub device mode
- Set 'Frequency hopping' to 'Off'
- Set 'Device auto register' to 'On'

Configure the repeaters to lock to the network.

Insert batteries in all devices for network 1

Let the pagers and call fobs register with the network.

Network 2

Power up the hub and set as follows:

- Assign a different network identifier
- Select a different radio channel for the hub device mode
- Set 'Frequency hopping' to 'Off'
- Set 'Device auto register' to 'On'

Configure the repeaters to lock to the network

Insert batteries in all devices for network 2

Let the repeaters register with the network

Move the pagers and call fobs out of range of network 1 and let the pagers and call fobs register with the network.

Manually setting up a multiple hub overlapping network or a mobile roaming network

Preparation

It is recommended that the repeaters serial numbers should be manually added to the hub device database before the batteries are inserted in the repeater. This prevents the repeater being denied access to the network as the system is set up.

Setting up the networks

For overlapping systems the networks should be set as follows:

Radio settings

Each radio network on the site must be assigned a unique network identifier.

Set 'Frequency hopping' to 'Off'.

Set 'Device auto register' to 'Off'.

Devices

Add repeaters/pagers/call fobs to the database manually via the 'Add' button on the 'Devices' screen.

Device mode

Hubs

The hubs should be set to different channels.

Repeaters

For overlapping networks set 'Lock to network'.

Pagers and call fobs

If the device is only to be used on an overlapping network then select 'Lock to network'. If the device is for a mobile roaming network do not lock to network.

Putting into service

Insert the battery into each repeater. The repeater will be allowed to join the correct network.

Appendix 5: Remote logging protocol

Overview of logging

The remote logging facility can be used for real time recording and remote storage of system events. Third parties are able to make use of the hub's remote logging output and external system input as a low level RS232 paging interface with higher level application software creating more sophisticated functions. For example, an application could be created to page staff members closest to the location where a request for assistance is made from, or to display the location of an individual on a graphical site plan, or to send an SMS message when a location alarm is raised.

The logging output from the hub supports output of the following message types:

Paging Messages

Output each time a paging message is sent or responded to

Location report

Output each time a device with location reporting enabled changes location

Personal security alarm

Output when PS alarms are raised/cleared

Maintenance message

Output when maintenance messages are raised e.g. low battery alarms from repeaters

Remote logging information is sent within a payload of syslog formatted messages. It is sent to UDP port 514 of the IP address specified on the system configuration page. No check is made to ensure that the machine is present.

Remote debug logging

The hub also supports low-level message debug logging. This can be used by Multitone for the diagnosis of network problems, but in a standard running system should be set to 'Off'. In order to differentiate between debug and event logging different syslog levels are used. Event logging is priority 'info' and debug logging is priority 'debug'.

General formatting

Remote logging messages can be set to numeric only, text only or a combination of numeric and text. These combinations allow the output to be easily human or machine readable as required.

Tabs delimit the fields.

All fields are present in all messages, even if empty, unless no more fields are to be filled in, where the line is then newline terminated.

Message always terminated by newline.

Output can be off, numeric, text or numeric and text.

Logging Protocol Format										
Field No	1	2	3	4	5	6	7	8	9	10
Type	Numeric							Text		
Name	Log Type	Message Type	Reason Code	Primary Hardware	Primary Serial No	Secondary Hardware	Secondary Serial No	Primary Name	Secondary Name	Message
	1 (PS) Personal Security	1 Raised	1 Dead Man 2 Man Down 3 Manual 4 Location					Device raising /clearing alarm	Location of device raising alarm OR Device accepting /rejecting alarm	Personal security alert text
		2 Accepted								
		3 Rejected								
		4 Cleared								
	2 (LO) Location	NA	NA					Device reporting its location	Location	
	3 (MT) Maintenance	1 Low Battery	NA					Device requiring maintenance	Not Applicable	Maintenance message
		2 Replace Battery	NA							
		3 Maintenance Required	NA							

Logging Protocol Format											
Field No	1	2	3	4	5	6	7	8	9	10	
Name	Log Type	Message Type	Reason Code	Primary Hardware	Primary Serial No	Secondary Hardware	Secondary Serial No	Primary Name	Secondary Name	Message	
Type	Numeric							Text			
	4 (PG) Paging	1 Message	1 No response Required		Individually addressed destination pager/ responding pager or 0,0 for broadcast or 0,pager group number for pager group	NA	NA	Blank for broadcast, or pager group name, or individual pager name	NA	Message text / delivery report / user response	
			2 Delivery report required								
			3 User response required								
			4 Delivery report & user response required								
			5 Externally generated message								
		2 Delivery Report	NA								
		3 Message Response	1 Accept								
	2 Reject										

Log examples

Key: Green: all syslog messages; yellow: numeric output selected; blue: text output selected.

PS: Call fob raising manual alarm at reception repeater

1	1	3	01 0	10000 39	030	00450 96	Call fob 1	Reception	Assist
---	---	---	---------	-------------	-----	-------------	---------------	-----------	--------

Note: the numbers in columns 4 to 7 are example serial number data. These will be repeated throughout, but are omitted for clarity.

PS: Pager accepting (manual) alarm raised by call fob

1	2	3	01 0	10000 39	020	00983 54	Call fob 1	Pager 1	Accepted
---	---	---	---------	-------------	-----	-------------	---------------	---------	----------

LO: Pager moving within range of hub

1			02 0	00983 54	001	00230 76	Pager 1	The Hub	
---	--	--	---------	-------------	-----	-------------	---------	---------	--

MT: Repeater not reporting status

3	1		03 0	00450 96			Recepti on		Maintenance Required
---	---	--	---------	-------------	--	--	---------------	--	-------------------------

PG: Message to all pagers, no response request

4	1	1	0	0					The Message Sent
---	---	---	---	---	--	--	--	--	------------------

PG: Message to pager group 1, response requested

4	1	3	0	1			Group 1		The Message Sent
---	---	---	---	---	--	--	------------	--	------------------

PG: Delivery report from pager

4	2		03 0	00450 96			Pager 1		Delivered
---	---	--	---------	-------------	--	--	---------	--	-----------

PG: Accept response from pager

4	3	1	03 0	00450 96			Pager 1		Accepted
---	---	---	---------	-------------	--	--	---------	--	----------

PG: Reject response from pager

4	3	2	03 0	00450 96			Pager 1		Rejected
---	---	---	---------	-------------	--	--	---------	--	----------

Appendix 6: External system connections

If the hub's external system interface is to be used, a link is connected to the serial port. The data rate should be set to the link speed (options are 300, 600, 1200, 2400, 4800 and 9600 bits per second). The data format and flow control should be set to match that of the receiving device (options are 7 bit even parity or 8 bit no parity with 1 or 2 stop bits). Messages will be truncated to 138 characters for TAP messages and 128 characters for ESPA messages.

Only a single selection from those below can be made on the hub; bidirectional paging operation is not supported.

Options are:

- ESPA input (maximum 138 characters). Note that 128 characters are defined by the standard
- ESPA output (maximum 101 characters, because only alarms are sent via this interface). Note that 128 characters are defined by the standard
- TAP input (maximum 138 characters)
- TAP output (maximum 101 characters, because only alarms are sent via this interface)

Incoming pager messages are addressed as follows:

0 = All pagers

1-32 = Pager group

HHHNNNNNNN for individual pagers where HHH = hardware type and NNNNNNNN = serial number.

Note: ESPA and TAP protocols do not have standardised third party implementations – a test with third party equipment is necessary.

Revision history and related documentation

Revision history

Issue	Date	Author	Revision
1	June 2007	M Windett	Initial Document
2	30.08.07	R Robertson	Production Issue
3	January 2008	M Windett	Update for System Release 3 Sub Release 1
4	July 2008	M Windett	Update for System Release 3 Sub Release 2
5	August 2008	D Neale	Corrections and addition of new products
6	18.06.09	Gooding	Latest Base and revise the drill diameter
7	03.11.09	D Neale	Added mains powered repeater

Related documentation

Title	Part Number
EkoTek Pager User Guide	9261-8275
EkoTek Hub User Guide	9261-8276
EkoTek Call Fob User Guide	9261-8277
EkoTek Call Fob Quick Instructions	9261-8311
EkoTek Pager Quick Instructions	9261-8312
EkoTek Hub Help Files (HTML)	4761-8313

Multitone Electronics plc
Multitone House
Shortwood Copse Lane
Kempshott
Basingstoke
Hampshire
RG23 7NL UK

Document number: 9261-8173